



RF Coaxial Connectors Catalog

## MCX



### Cmptter Electronics Co., Limited

#2-3F, SaiQiElectronicsPark, Dantu New city  
Industry area, ZhenJiangCity, 212028, JS, China  
Tel: (86) 511 8443 6131  
Email: sales@cmptter.com  
Web: www.cmptter.com

# MCX Series Coaxial Connectors



## DESCRIPTION

MCX connectors are developed in Europe during the 1980s, use a snap-on interface, a blend of size, reliability and performance. Though smaller and lighter than the SMB by approximately 30%, the MCX still preserves the SMB's inner contact and overlapping dielectric insulator dimensions so that it can provide consistent electronic performance from DC-6 GHz.

Miniature snap-on connectors which offer an excellent blend of size, weight, durability, and performance for applications such as GPS, wireless communication, base station, WLAN, fixed communication systems, testing, and instrumentation applications.

## CONTENTS

Description .....	1
Interface dimensions .....	2
Technical data .....	3
Cable connectors .....	4
PCB Connectors .....	7
Assembly instruction .....	8
Mounting Holes .....	13

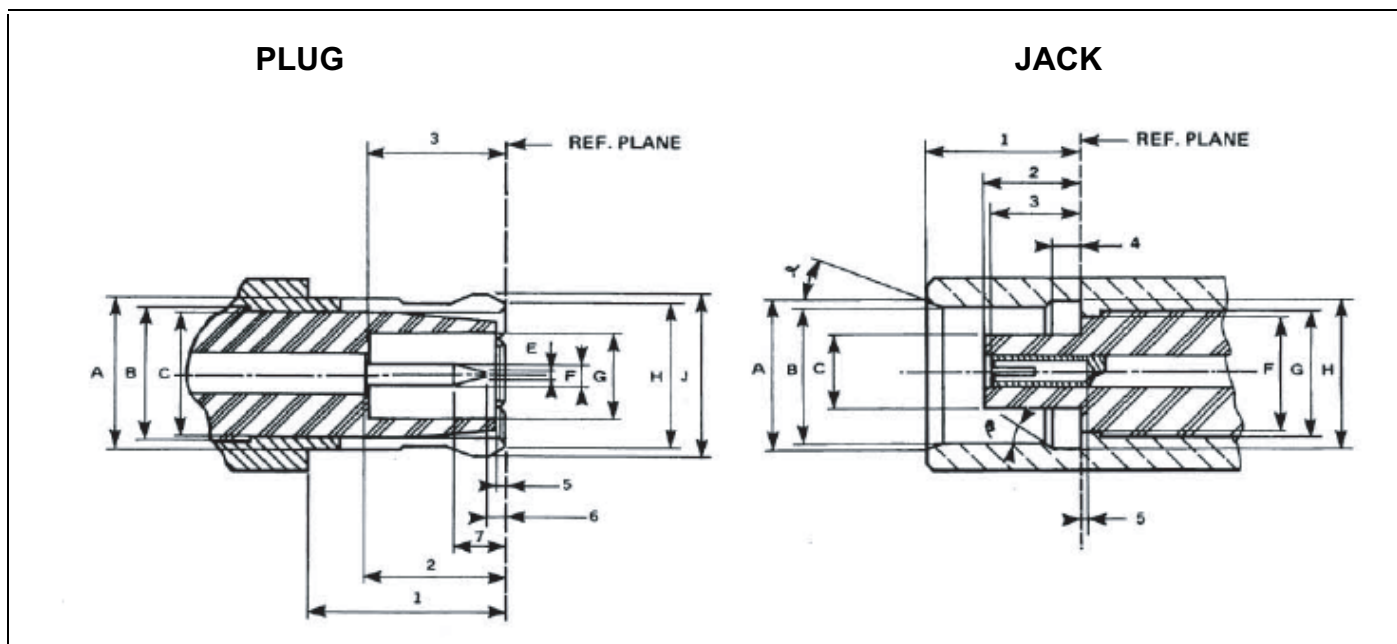

LETTER	mm		inch	
	min.	max.	min.	max.
1	4.15	-	.163	
2	2.80	3.2	.110	.126
3	2.80		.110	
5	0	0.30	0	.012
6	0.15		0.06	
7		1.20		0.47
A		3.40		1.34
B	3.05 NOM.		.120 NOM.	
C		3.00		.118
E		0.25		0.10
F	0.48	0.53	0.19	.021
G	2.00		.079	
H		3.60		.142
J		3.80		.150

LETTER	mm		inch	
	min.	max.	min.	max.
1	4.00	4.12	.157	.162
2	2.60	2.80	.102	.110
3	2.30	2.80	.090	.110
4	0.75	0.85	.029	.033
5	0		0	
$\alpha$	18°	22°	18°	22°
$\beta$	43°	47°	43°	47°
A	3.80		.150	
B	3.42	3.48	.135	.137
C		1.98		.078
F		3.00		.118
G	3.05 NOM.		3.05 NOM.	
H	3.60	3.75	.142	.148

**Interface dimensions conformable to the standards:**

International: **IEC 61169-4**  
 Europe: **CECC 22190**  
 Germany: **DIN 47223, VG 95250**

**IP rating (interface, mated) IP68**

# TECHNICAL DATA



ELECTRICAL DATA	
Impedance	50 Ohm
Frequency range	DC 0-6 GHz
Voltage Rating	250 V peak
V.S.W.R.	Straight styles: 1.20 Right angle styles: 1.25
Insulation resistance	10,000 M $\Omega$
Contact resistance	Center contact: 6 $\Omega$ ; Outer contact: 3 $\Omega$

MECHANICAL DATA	
Mating	Slide-on, push-pull, threaded
Connector Durability (matings)	500 mating

MATERIAL DATA	
Male Contact	Brass
Female contact	Beryllium copper center and outer, gold plated
Insulator	Teflon
Crimp Ferrule	Copper

ENVIRONMENTAL	
Temperature Range	-40 °C to + 155 °C
Thermal shock	MIL STD 202 - method 107 condition C
High temperature test	MIL STD 202 - method 108A condition D
Corrosion	MIL STD 202 - method 101 condition B
Vibration	MIL STD 202, method 204, condition D

# CABLE CONNECTORS



## Straight cable plugs (male)



P/N	Cable Type	Finish		Assembly Instruction	Notes
		Center	Body		
30-03-1M04-001	LMR100/RG174/RG316	Gold	Gold	A01	

- > Cable entry crimp
- > Centre contact soldered

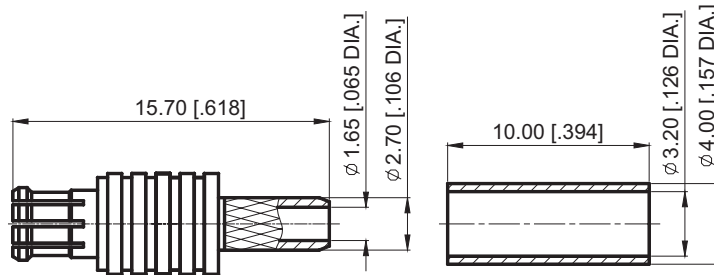

P/N	Cable Type	Finish		Assembly Instruction	Notes
		Center	Body		
30-03-1M12-002	RG178	Gold	Gold	A01	

- > Cable entry crimp
- > Centre contact soldered

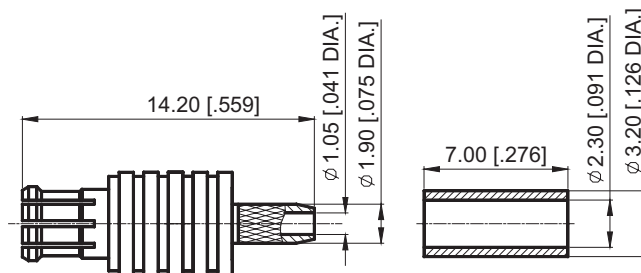

P/N	Cable Type	Finish		Assembly Instruction	Notes
		Center	Body		
30-03-2M11-004	Semi-rigid .086/RG405	Gold	Gold	A02	

- > Cable entry soldered
- > Centre contact soldered

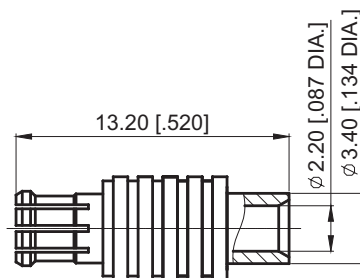

# CABLE CONNECTORS



## Right angle cable plugs (male)



P/N	Cable Type	Finish		Assembly Instruction	Notes
		Center	Body		

30-13-1M04-005

LMR100/RG174/RG316

Gold

Gold

A03

- > Cable entry crimp
- > Centre contact soldered

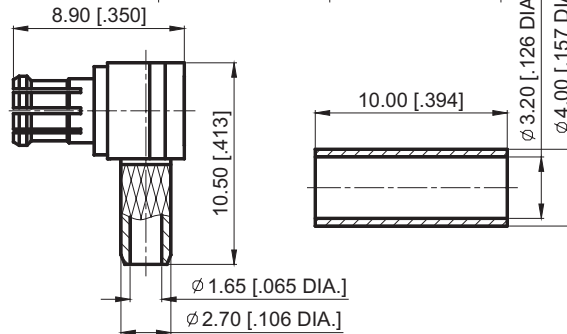

P/N	Cable Type	Finish		Assembly Instruction	Notes
		Center	Body		

30-13-1M12-006

RG178

Gold

Gold

A03

- > Cable entry crimp
- > Centre contact soldered

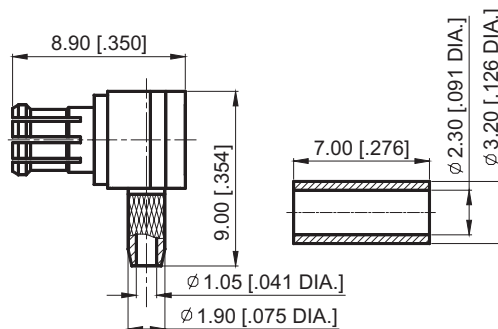

P/N	Cable Type	Finish		Assembly Instruction	Notes
		Center	Body		

30-13-2M06-007

RG402/Semi-rigid .141

Gold

Gold

A04

- > Cable entry crimp
- > Centre contact soldered

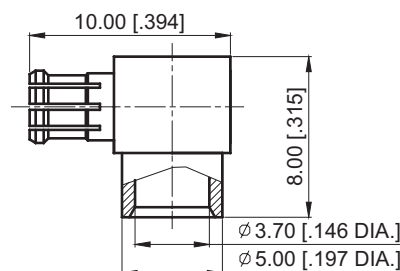

# CABLE CONNECTORS



## Straight cable jacks(female)



P/N	Cable Type	Finish		Assembly Instruction	Notes
		Center	Body		
30-02-1M04-010	LMR100/RG174/RG316	Gold	Gold	A01	

- > Cable entry crimp
- > Centre contact soldered

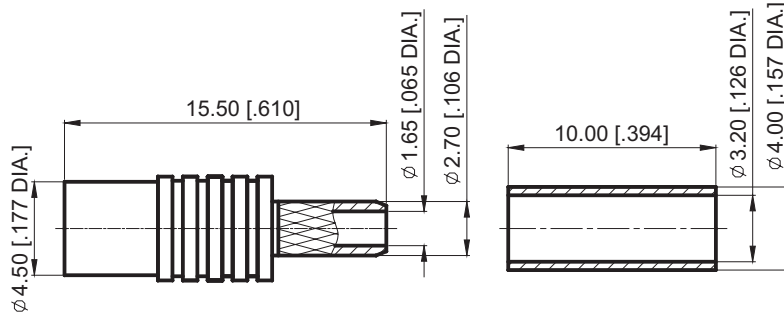

P/N	Cable Type	Finish		Assembly Instruction	Notes
		Center	Body		
30-02-1M12-011	RG178	Gold	Gold	A01	

- > Cable entry crimp
- > Centre contact soldered

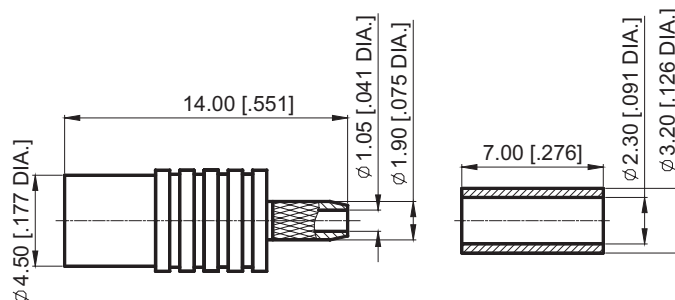

P/N	Cable Type	Finish		Assembly Instruction	Notes
		Center	Body		
30-02-2M23-012	1.13mm/1.32mm/ 1.37mm Cable	Gold	Gold	A05	

- > Cable entry solder
- > Centre contact soldered

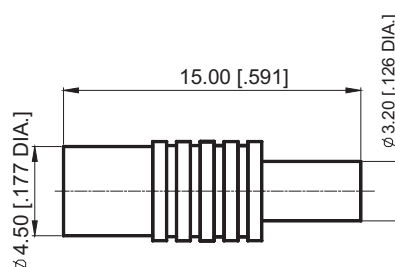

# PCB CONNECTORS



## PCB jacks(female)



P/N	Mount Hole	Finish		Notes
		Center	Body	
30-02-5L2-013	M01	Gold	Gold	

> With stand-off

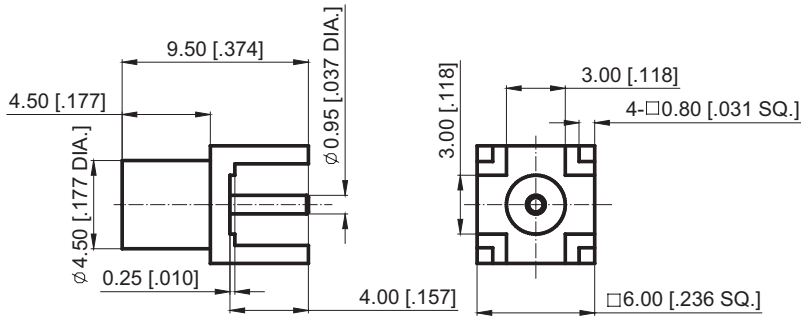

P/N	Soldering Pads	Finish		Notes
		Center	Body	
30-12-5L2-014	M01	Gold	Gold	

> With stand-off

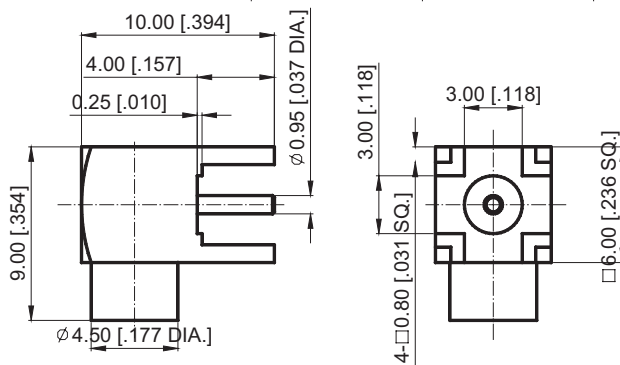

P/N	Mount Hole	Finish		Notes
		Center	Body	
30-12-6L2-015	M02	Gold	Gold	

> SMT mounted

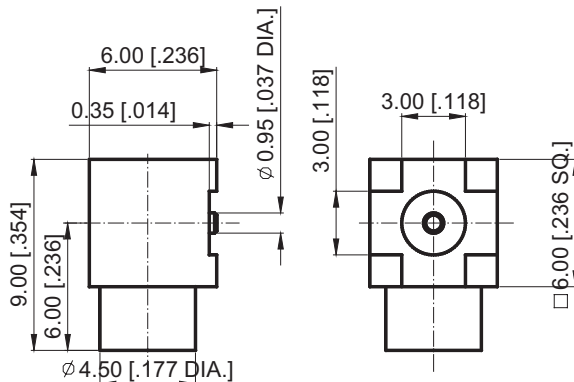



# ASSEMBLY INSTRUCTIONS



## A01

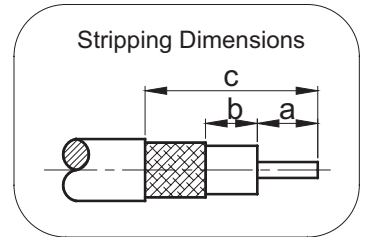
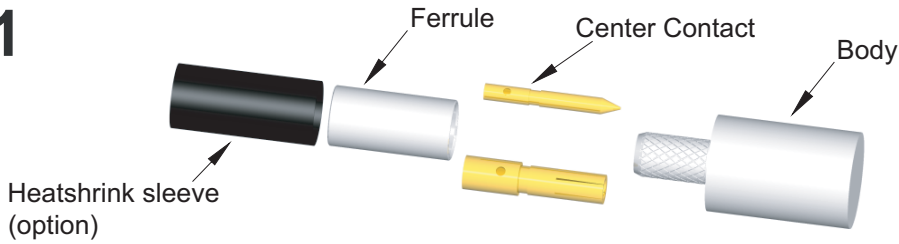

P/N	Cable Type	HEX. Crimp Tool (mm [in])	Stripping Length (mm [in])		
			a	b	c
30-03-1M12-002	RG178	2.54 [.100]	2.5 [.098]	2 [.079]	8.5 [.335]
30-02-1M12-011					
30-03-1M04-001	LMR100/RG174/RG316	3.25 [.128]	2.5 [.098]	2 [.079]	10 [.394]
30-02-1M04-010					

- Slide the heatshrink sleeve onto the cable (option).
- Slide the ferrule onto the cable.
- Strip the cable as Stripping Dimensions.



- Slide the center contact on until it bottom against the cable dielectric.
- Solder the center contact onto the cable.



- Fan the braid.



- Slide the cable into the body until stops.



- Slide the ferrule over the braid.
- Crimp the ferrule with crimping tool (see table).

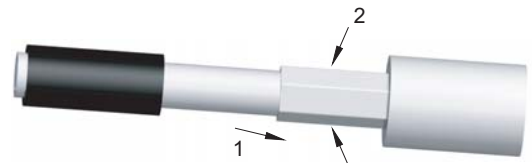

- Cut the excess of braid if necessary.
- Slide the sleeve over the ferrule and heatshrink it in place (option).

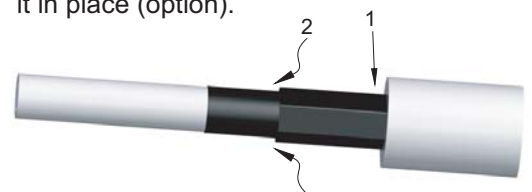

# ASSEMBLY INSTRUCTIONS

## A02

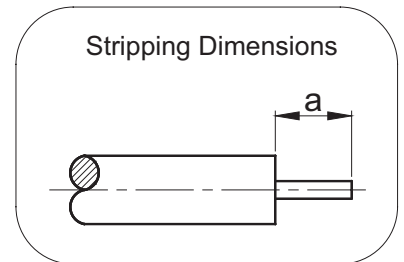
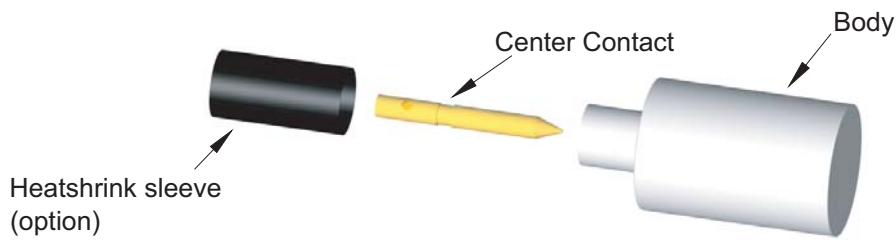

P/N	Cable Type	Stripping Length (mm [in])	Notes
30-03-2M11-004	RG405/Semi-rigid .086	3.00 [.118]	

- Slide the heatshrink sleeve onto the cable (option).  
Strip the cable as Stripping Dimensions.



- Slide the center contact on until it bottom against the cable dielectric.  
Solder the center contact onto the cable.



- Slide the cable into the body until it stops.

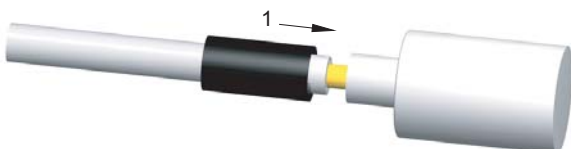

- Solder the body onto the cable.

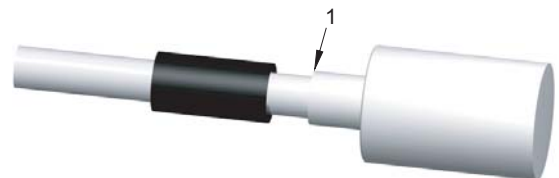

- Slide the heatshrink sleeve over the body and heatshrink it in place (option).

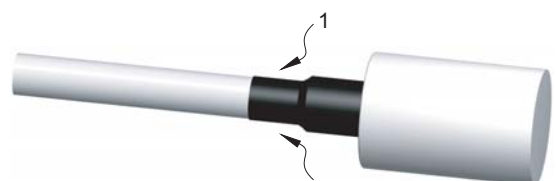

# ASSEMBLY INSTRUCTIONS



## A03

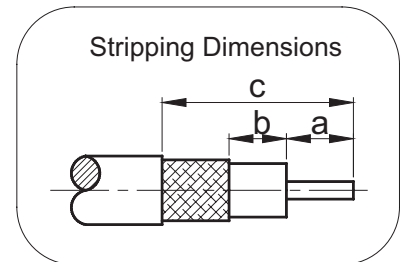
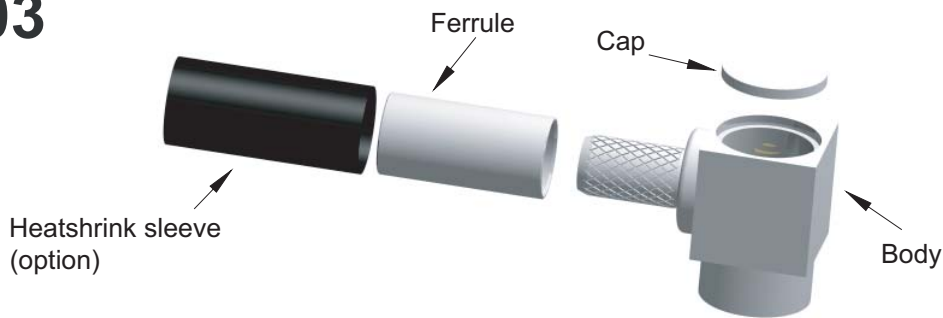

P/N	Cable Type	HEX. Crimp Tool (mm [in])	Stripping Length (mm [in])		
			a	b	c
30-13-1M12-006	RG178	2.54 [.100]	1.2 [.047]	2.3 [.091]	7.5 [.295]
30-13-1M04-005	LMR100/RG174/RG316	3.25 [.128]	1.2 [.047]	2.3 [.091]	9 [.354]

- Slide the heatshrink sleeve onto the cable (option).  
Slide the ferrule onto the cable.  
Strip the cable as Stripping Dimensions.



- Fan the braid.



- Push the body under the braid.  
Slide the ferrule over the braid.

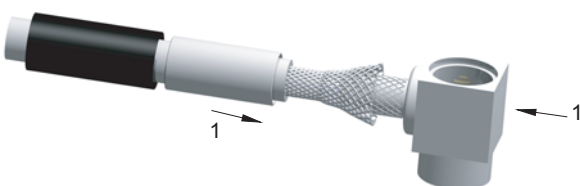

- Crimp the ferrule with crimping tool (see table).  
Solder the inner conductor.

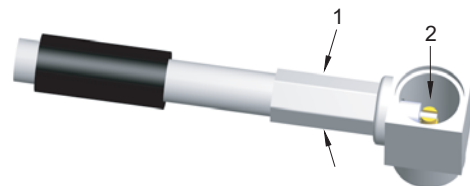

- Place the cap into the body.



- Press on the cap until stops.  
Slide the sleeve over the ferrule and heatshrink it in place (option).

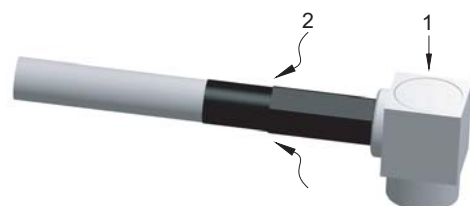

# ASSEMBLY INSTRUCTIONS



## A04

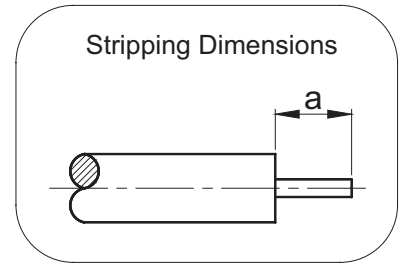

P/N	Cable Type	Stripping Length (mm [in])	Notes
30-13-2M06-007	RG402/Semi-rigid .141	3 [.118]	

- Slide the heatshrink sleeve onto the cable (option).
  - Strip the cable as Stripping Dimensions.



- Slide the cable into the body until it stops.
  - Solder the inner conductor.

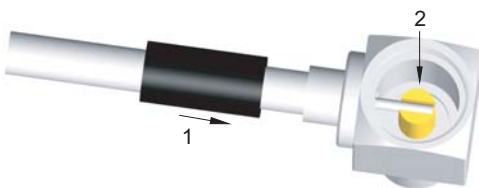

- Solder the cable onto the body.
  - Screw the back nut onto the body.

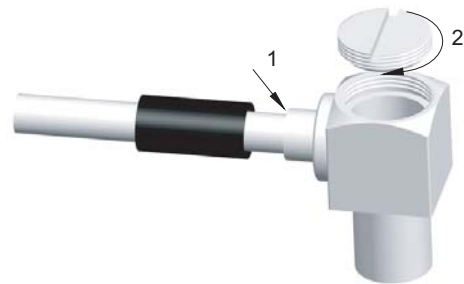

- Slide the sleeve over the body and heatshrink it in place (option).



# ASSEMBLY INSTRUCTIONS



## A05

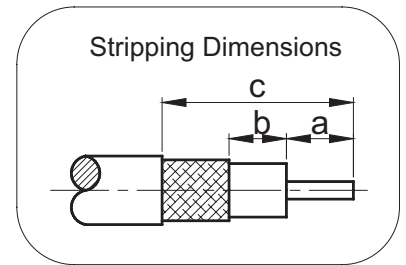
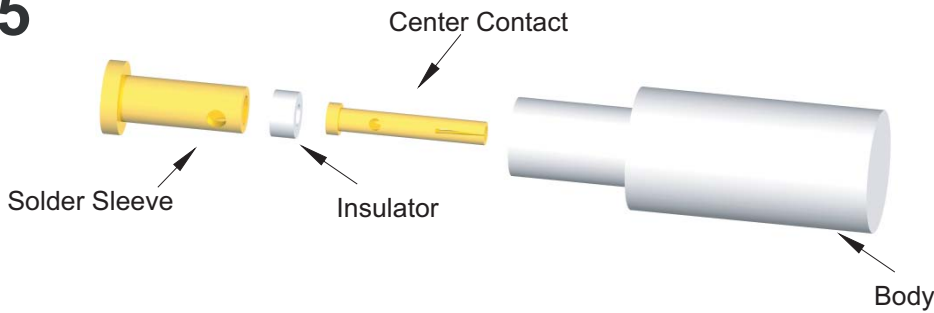

P/N	Cable Type	HEX. Crimp Tool (mm [in])	Stripping Length (mm [in])		
			a	b	c
30-03-1M12-002	1.13mm/1.32mm/1.37mm Cable	2.54 [.100]	2.5 [.098]	1 [.039]	11 [.433]

- Strip the cable as Stripping Dimensions.  
Soaking the inner and outer conductor with tin.



- Slide the Solder Sleeve onto the outerductor.  
Solder the Solder Sleeve onto the cable (ensure the position of the Solder Sleeve).



- Slide the Insulator onto the dielectric until it stops.  
Slide the Center Contact onto the cable until it stops.  
Solder the Center Contact onto the cable.



- Slide the cable into body until it stops.

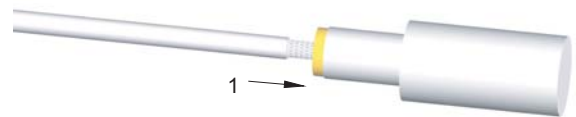

- Crimp the Body with crimping tool (see table).  
Slide a Heatshrink Sleeve over the Body and heatshrink it in place (option).

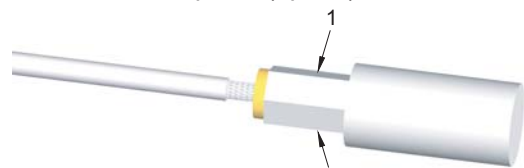

# MOUNTING HOLES

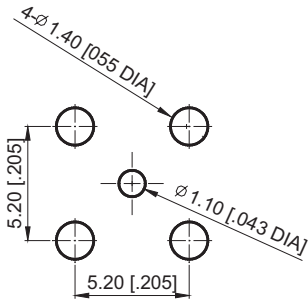

M01

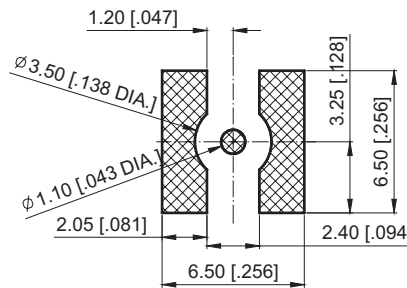

M02