

REVISIONS				
REV	DESCRIPTION OF REVISION	ECN No.	DATE	APPROVED
A	INITIAL RELEASE	—	04/11/2014	M. Dong

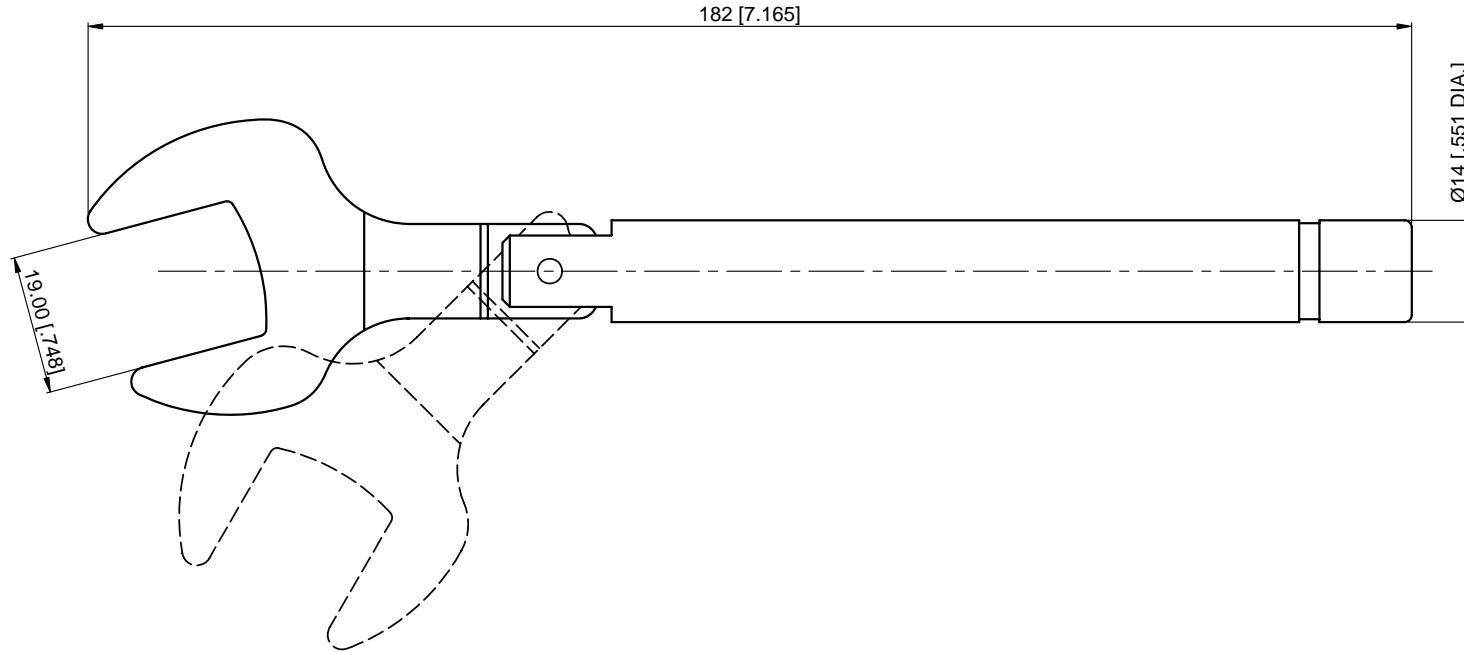

Preset Torque: 1.48Nm [13.0 in. lbs]

NOTES:

1. ALL SPECIFICATIONS ARE SUBJECT TO CHANGE WITHOUT NOTICE AT ANY TIME
2. UNLESS OTHERWISE SPECIFIED ALL DIMENSIONS ARE NOMINAL.

UNLESS OTHERWISE SPECIFIED, DIMENSIONS ARE IN MILLIMETERS [INCHES]. UNLESS OTHERWISE SPECIFIED DIMENSIONAL TOLERANCES ARE:	
.XX	±0.13 [0.005"]
.X	±0.20 [0.008"]
X	±0.50 [0.019"]
ANGULAR TOLERANCES ARE: ALL ±1°	
DO NOT SCALE DRAWING	
PROJECTION:	

DRAWN:	L. Ma	04/11/2014
CHECKED:	J. Zhu	04/11/2014
APPROVED:	M. Dong	04/11/2014

TITLE:  
**Preset Torque Wrench With  
 19mm Bit For N Type  
 Connectors**

Cmptter Electronics Co., Ltd. <a href="http://www.cmptter.com">www.cmptter.com</a>			
PART No.: <b>TW-009</b>			
SIZE: A4	SCALE: 1:1	SHEET: 1/1	REV: A