

A B C D E F G H I J

REVISIONS				
REV	DESCRIPTION OF REVISION	ECN No.	DATE	APPROVED
A	INITIAL RELEASE	—	03/12/2018	M. Dong

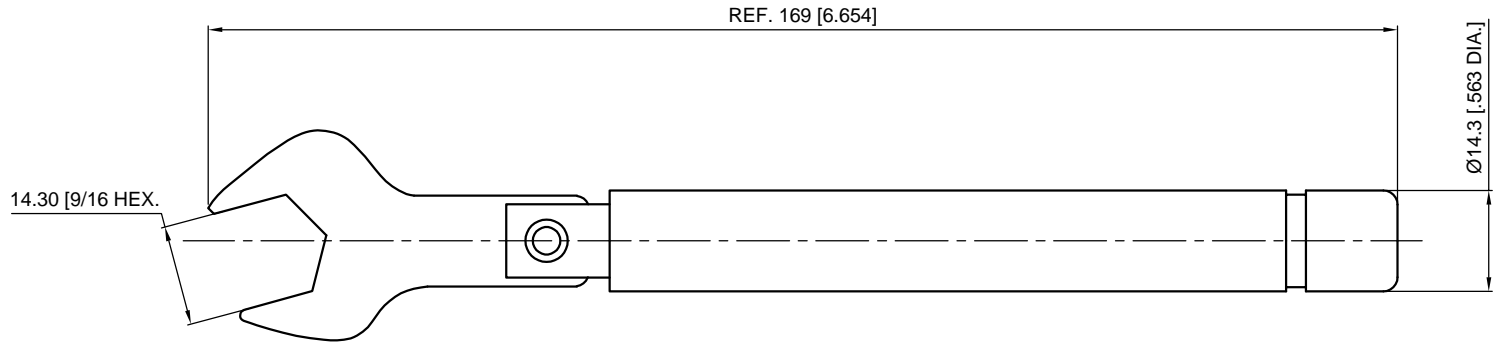

Preset Torque: 1.36±0.05 Nm [12±0.48 in. lbs]

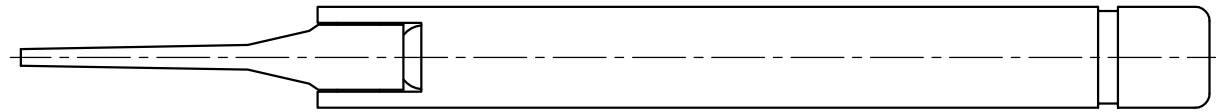

- NOTES:
1. ALL SPECIFICATIONS ARE SUBJECT TO CHANGE WITHOUT NOTICE AT ANY TIME
  2. UNLESS OTHERWISE SPECIFIED ALL DIMENSIONS ARE NOMINAL.

UNLESS OTHERWISE SPECIFIED, DIMENSIONS ARE IN MILLIMETERS [INCHES]. UNLESS OTHERWISE SPECIFIED DIMENSIONAL TOLERANCES ARE: .XX ±0.13 [.005"] X ±0.20 [.008"] X ±0.50 [.019"] ANGULAR TOLERANCES ARE: ALL=±1° DO NOT SCALE DRAWING PROJECTION:
--

DRAWN:	L. Ma	03/12/2018
CHECKED:	J. Zhu	03/12/2018
APPROVED:	M. Dong	03/12/2018

TITLE:  
Preset Torque Wrench With  
14.3mm [9/16 IN.] Bit For TNC Type  
Connectors, 1.36 NM[12 IN.LBS]

**CMP<sub>TER</sub>**®  
Cmpt<sub>er</sub> Electronics Co., Ltd. [www.cmpt<sub>er</sub>.com](http://www.cmpt<sub>er</sub>.com)

PART No.: **TW-016**

SIZE: A4	SCALE: 1:1	SHEET: 1/1	REV: A
----------	------------	------------	--------

A B C D E F G H I J