

REV	DESCRIPTION OF REVISION	ECN No.	BY	DATE	APPROVED
A	INITIAL RELEASE	—	L. Ma	06/03/10	M. Dong
B	DIMENSION CHANGED	—	L. Ma	10/26/13	M. Dong

TECHNICAL DATA

Electrical data

Impedance	50 Ω
Frequency range	0~3 GHz
Insulation resistance	≥5×10 ³ MΩ
Withstanding voltage	1000 V

Mechanical data

Temperature range	-65 °C ~ +165 °C
Durability (matings)	>500

Material data

Bodies	Brass, Nickel-plated
Pin Contact	Phosphor Bronze, Gold-plated
Fastening nut	Brass, Nickel-plated
Insulator	PTFE
Gasket	Silicone rubber

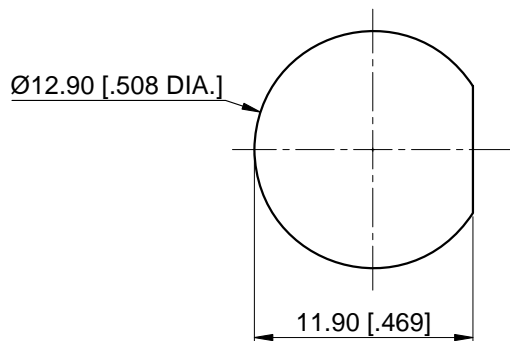
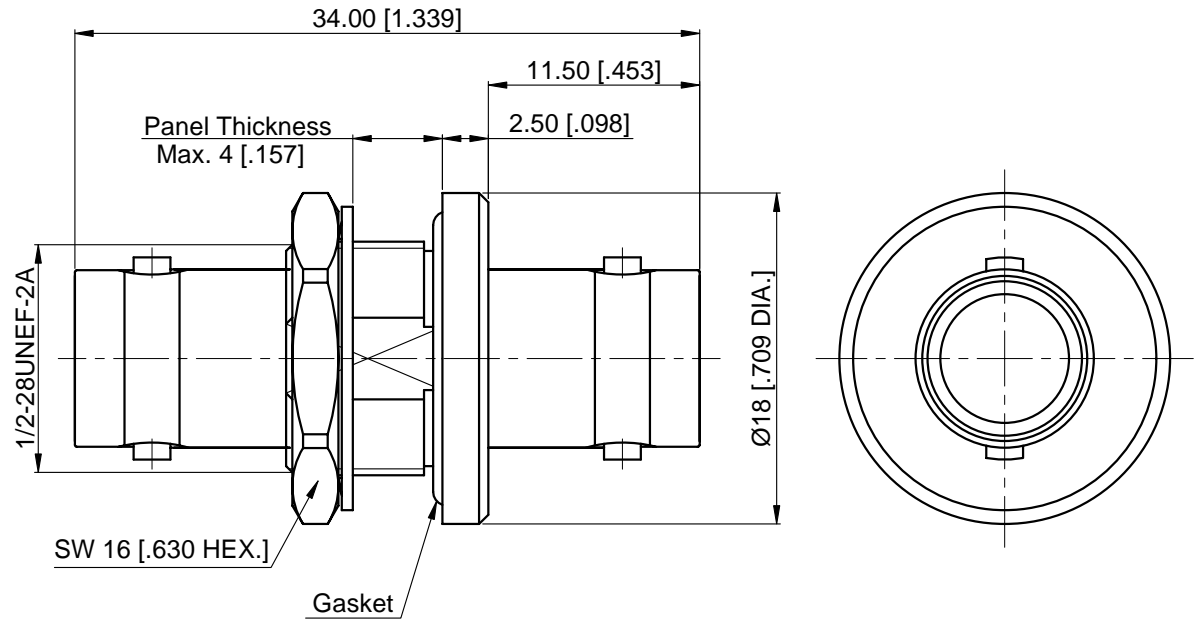

Recommended Mounting Hole

NOTES:

- ALL SPECIFICATIONS ARE SUBJECT TO CHANGE WITHOUT NOTICE AT ANY TIME
- CUSTOMER OUTLINE DRAWING FOR REFERENCE ONLY

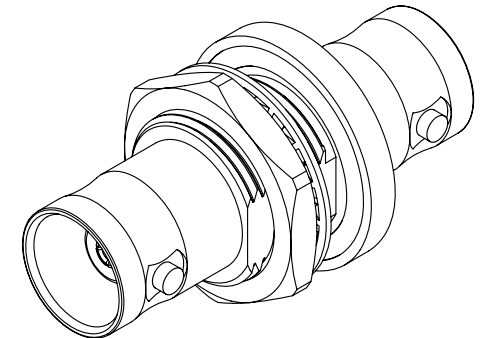

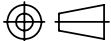
DRAWN: L. Ma 10/26/13	TITLE:	 www.cmptter.com				
ENGINEER: J. Zhu 10/26/13	Adapter, BNC Bulkhead Waterproof Female to BNC Female					
APPROVED: M. Dong 10/26/13		 DIMENSIONS IN MILLIMETERS (mm)	SIZE:	SCALE:	SHEET:	REV:
TOLERANCE UNLESS OTHERWISE SPECIFIED	PART No.: A-BNCF-BNCF-077		A4	2.5:1	1/1	B
X ±0.50 [.019"]						
.X ±0.20 [.008"]						
.XX ±0.10 [.004"]						
ANGLES ±1°						