

TECHNICAL DATA

Electrical

Impedance	50 Ω
Frequency range	0~6 GHz
VSWR	1.25:1
Withstanding voltage	335 V
Insulation resistance	≥1000MΩ

Mechanical & Environmental

Durability (matings)	>500
Temperature range	-55 °C ~ +165 °C
RoHS Compliant	Yes

Material & Finish

Body	Brass, Gold-plated
Pin Contact	Phosphor Bronze, Gold-plated
Insulator	PTFE

Interface Standards

SMA	IEC-60169-15
SMB	IEC-60169-10

REVISIONS				
REV	DESCRIPTION OF REVISION	ECN No.	DATE	APPROVED
A	INITIAL RELEASE	—	06/19/2013	M. Dong
B	STRUCTURE CHANGED	—	03/21/2015	M. Dong

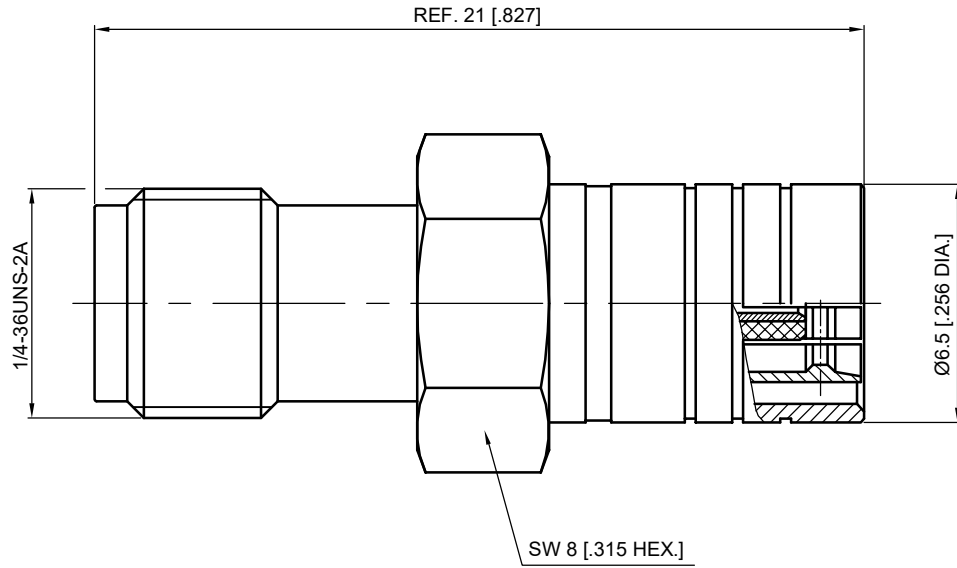

UNLESS OTHERWISE SPECIFIED, DIMENSIONS ARE IN MILLIMETERS (INCHES).
UNLESS OTHERWISE SPECIFIED DIMENSIONAL TOLERANCES ARE:

.XX	±0.13 [.005"]
.X	±0.20 [.008"]
X	±0.50 [.019"]

ANGULAR TOLERANCES ARE: ALL= ±1°

DO NOT SCALE DRAWING

PROJECTION:

DRAWN:	L. Ma	03/21/2015
CHECKED:	J. Zhu	03/21/2015
APPROVED:	M. Dong	03/21/2015

TITLE:
Adapter, SMA Female to SMB Plug (Female Center Contact)



Cmppter Electronics Co., Ltd. www.cmppter.com

PART No.:
A-SMAF-SMBM-219

SIZE: A4	SCALE: 5:1	SHEET: 1/1	REV: B
----------	------------	------------	--------

NOTES:

- ALL SPECIFICATIONS ARE SUBJECT TO CHANGE WITHOUT NOTICE AT ANY TIME
- UNLESS OTHERWISE SPECIFIED ALL DIMENSIONS ARE NOMINAL.