

TECHNICAL DATA

Electrical

Impedance	50 Ω
Frequency range	0~50 GHz
VSWR	1.15:1
Contact resistance	
-centre contact	≤3mΩ
-outer contact	≤2mΩ
Insulation resistance	≥3000MΩ

Mechanical & Environmental

Durability (matings)	>500
Temperature range	-55 °C ~ +165 °C
RoHS Compliant	Yes

Material & Finish

Body	Stainless Steel (SU303), Passivated
Pin Contact	Beryllium Copper Alloy, Gold-plated
Insulator	PEI , PTFE

Interface Standards

2.4mm	IEEE STD 287-2007
-------	-------------------

Part Number	D	L
97-02-9E2-026 A	0.75 [.029]	9 [.354]
97-02-9E2-026 B	0.86 [.034]	8.75 [.344]
97-02-9E2-026 C	1 [.040]	5.5 [.216]
97-02-9E2-026 D	1.04 [.041]	6.34 [.250]
97-02-9E2-026 E	1.2 [.047]	3 [.118]
97-02-9E2-026 F	0.64 [.025]	10 [.394]
97-02-9E2-026 G	0.64 [.025]	6.84 [.1269]

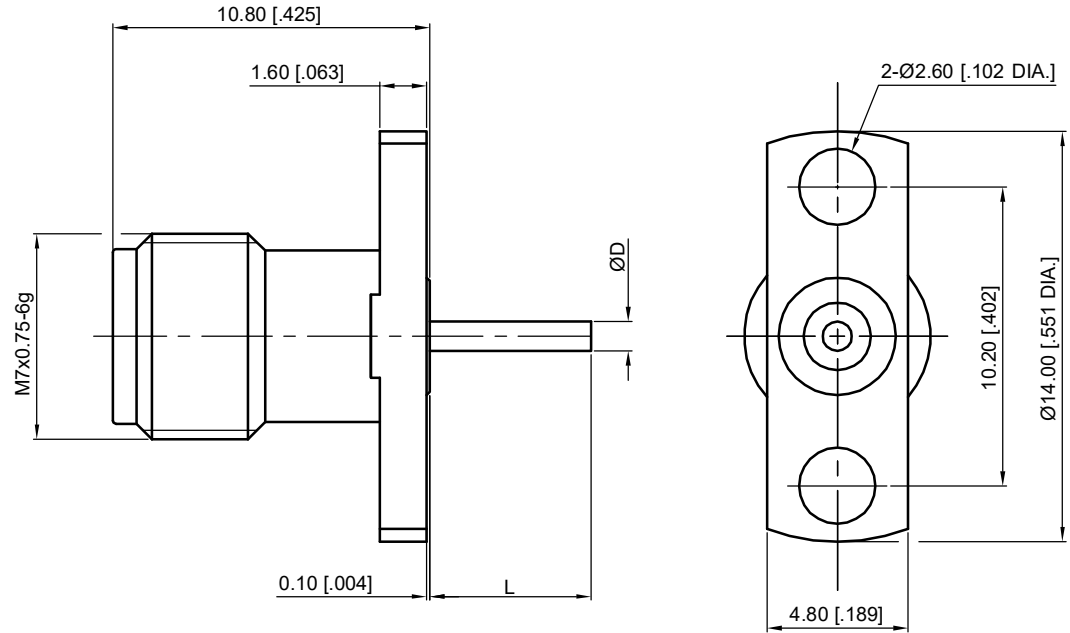

REVISIONS				
REV	DESCRIPTION OF REVISION	ECN No.	DATE	APPROVED
A	INITIAL RELEASE	---	08/10/2010	M. Dong
B	ADD TYPE F & G	---	10/18/2016	M. Dong

NOTES:

- ALL SPECIFICATIONS ARE SUBJECT TO CHANGE WITHOUT NOTICE AT ANY TIME
- UNLESS OTHERWISE SPECIFIED ALL DIMENSIONS ARE NOMINAL.

UNLESS OTHERWISE SPECIFIED, DIMENSIONS ARE IN MILLIMETERS (INCHES).
UNLESS OTHERWISE SPECIFIED DIMENSIONAL TOLERANCES ARE:

.XX	±0.13 [.005"]
.X	±0.20 [.008"]
X	±0.50 [.019"]

ANGULAR TOLERANCES ARE: ALL= ±1°

DO NOT SCALE DRAWING

PROJECTION:



DRAWN:	L. Ma	10/18/2016
CHECKED:	J. Zhu	10/18/2016
APPROVED:	M. Dong	10/18/2016

TITLE:
**2.4mm Straight Female,
Air Line Through the Wall,
2 Hole Flange**



Cmppter Electronics Co., Ltd. www.cmppter.com

PART No.:
97-02-9E2-026

SIZE: A4	SCALE: 4:1	SHEET: 1/1	REV: B
-------------	---------------	---------------	-----------