

TECHNICAL DATA

Electrical

Impedance	50 Ω
Frequency range	0~50 GHz
VSWR	1.15:1
Contact resistance	
-centre contact	≤3mΩ
-outer contact	≤2mΩ
Insulation resistance	≥3000MΩ

Mechanical & Environmental

Durability (matings)	>500
Temperature range	-55 °C ~ +165 °C
RoHS Compliant	Yes

Material & Finish

Body	Stainless Steel (SU303), Passivated
Pin Contact	Beryllium Copper Alloy, Gold-plated
Insulator	PEI , PTFE

Interface Standards

2.4mm	IEEE STD 287-2007
-------	-------------------

REVISIONS				
REV	DESCRIPTION OF REVISION	ECN No.	DATE	APPROVED
A	INITIAL RELEASE	—	08/10/2010	M. Dong
B	ADD TYPE D	—	10/18/2016	M. Dong

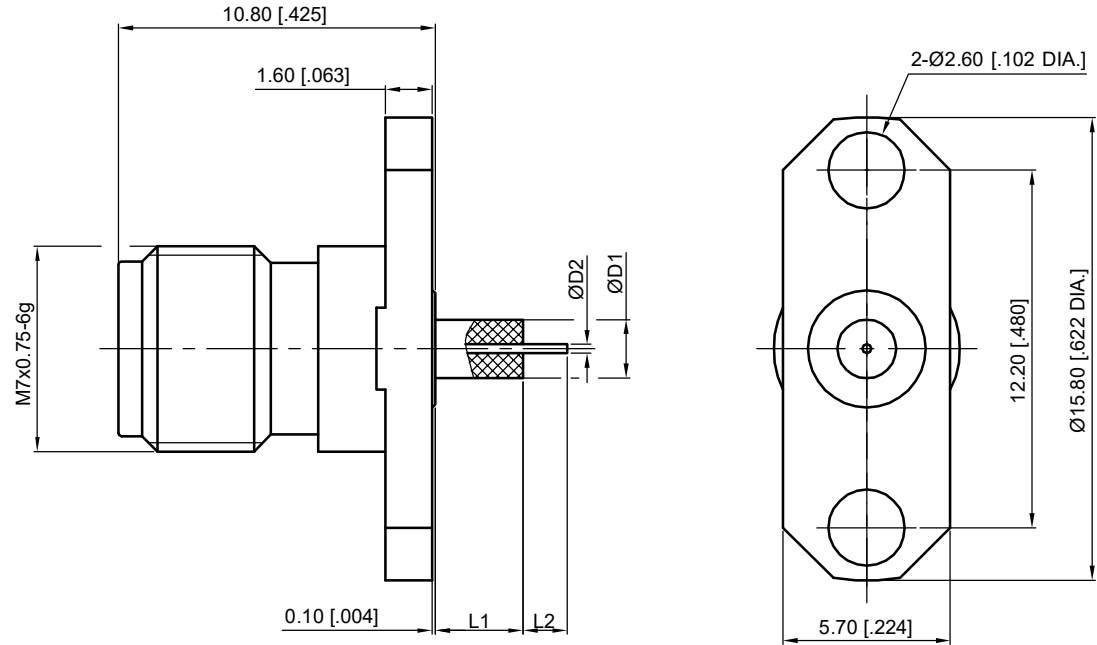

Part Number	D1	D2	L1	L2
97-02-9E7-020 A	1.67 [.066]	0.3 [.012]	1.4 [.055]	1.5 [.059]
97-02-9E7-020 B	1.67 [.066]	0.3 [.012]	3 [.118]	1.5 [.059]
97-02-9E7-020 C	2 [.078]	0.6 [.024]	6.35 [.250]	1.27 [.050]
97-02-9E7-020 D	2 [.078]	0.6 [.024]	5.1 [.200]	1.9 [.075]

NOTES:

- ALL SPECIFICATIONS ARE SUBJECT TO CHANGE WITHOUT NOTICE AT ANY TIME
- UNLESS OTHERWISE SPECIFIED ALL DIMENSIONS ARE NOMINAL.

UNLESS OTHERWISE SPECIFIED, DIMENSIONS ARE IN MILLIMETERS (INCHES).
UNLESS OTHERWISE SPECIFIED DIMENSIONAL TOLERANCES ARE:

.XX ±0.13 [.005]
.X ±0.20 [.008]
X ±0.50 [.019]

ANGULAR TOLERANCES ARE: ALL= ±1°

DO NOT SCALE DRAWING

PROJECTION:

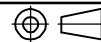

DRAWN:	L. Ma	10/18/2016
CHECKED:	J. Zhu	10/18/2016
APPROVED:	M. Dong	10/18/2016

TITLE:
**2.4mm Straight Female,
Insulator Through the Wall,
4 Hole Flange**

CMPPTER®

Cmppter Electronics Co., Ltd. www.cmppter.com

PART No.:
97-02-9E7-020

SIZE: A4	SCALE: 4:1	SHEET: 1/1	REV: B
-------------	---------------	---------------	-----------