

REVISIONS				
REV	DESCRIPTION OF REVISION	ECN No.	DATE	APPROVED
A	INITIAL RELEASE	---	07/21/2012	M. Dong
B	ADD TYPE C	---	10/15/2016	M. Dong

TECHNICAL DATA

Electrical

Impedance	50 Ω
Frequency range	0~40 GHz
VSWR	1.15:1
Contact resistance	
-centre contact	≤3mΩ
-outer contact	≤2mΩ
Insulation resistance	≥3000MΩ

Mechanical & Environmental

Durability (matings)	>500
Temperature range	-55 °C ~ +165 °C
RoHS Compliant	Yes

Material & Finish

Body	Stainless Steel (SU303), Passivated
Pin Contact	Beryllium Copper Alloy, Gold-plated
Insulator	PEI, PTFE

Interface Standards

2.92mm	MIL-STD-348A
--------	--------------

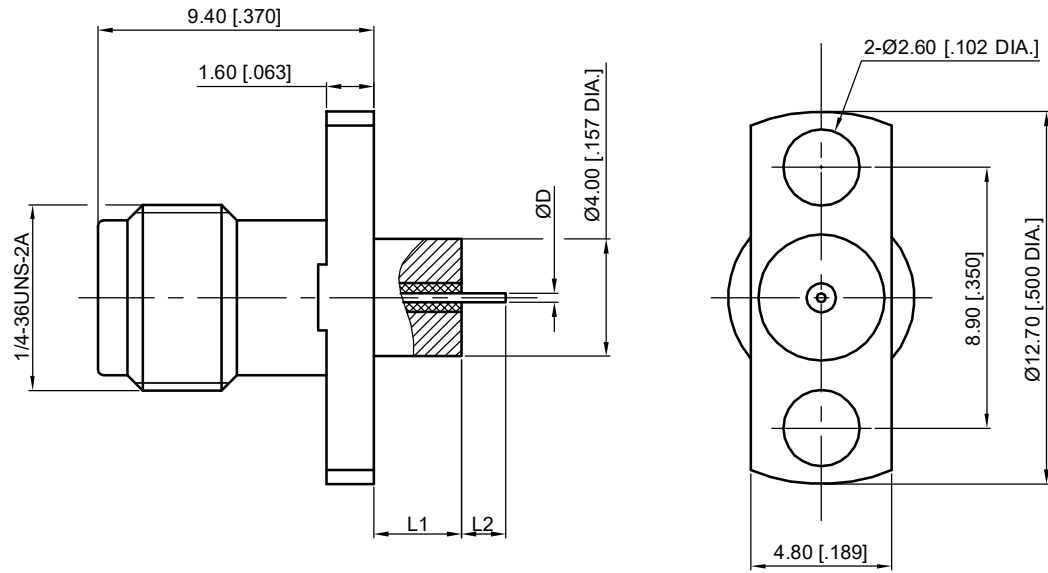

Part Number	ØD	L1	L2
96-02-9E2-017 A	0.30 [0.012]	1.4 [0.055]	1.5 [0.059]
96-02-9E2-017 B	0.30 [0.012]	3 [0.118]	1.5 [0.059]
96-02-9E2-017 C	0.60 [0.024]	10.1 [0.398]	1.27 [0.050]

UNLESS OTHERWISE SPECIFIED, DIMENSIONS ARE IN MILLIMETERS (INCHES).
UNLESS OTHERWISE SPECIFIED DIMENSIONAL TOLERANCES ARE:

.XX ±0.13 [0.005]
.X ±0.20 [0.008]
X ±0.50 [0.019]

ANGULAR TOLERANCES ARE: ALL= ±1°

DO NOT SCALE DRAWING

PROJECTION:

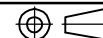

DRAWN:	L. Ma	10/15/2016
CHECKED:	J. Zhu	10/15/2016
APPROVED:	M. Dong	10/15/2016

TITLE:
**2.92mm Straight Female,
Metal Through the Wall,
2 Hole Flange**

CMPPTER®

Cmppter Electronics Co., Ltd. www.cmppter.com

PART No.:
96-02-9E2-017

SIZE: A4	SCALE: 4:1	SHEET: 1/1	REV: B
-------------	---------------	---------------	-----------

NOTES:

- ALL SPECIFICATIONS ARE SUBJECT TO CHANGE WITHOUT NOTICE AT ANY TIME
- UNLESS OTHERWISE SPECIFIED ALL DIMENSIONS ARE NOMINAL.