

REVISIONS

REV	DESCRIPTION OF REVISION	ECN No.	DATE	APPROVED
A	INITIAL RELEASE	---	07/21/2012	M. Dong
B	ADD TYPE D	---	10/16/2016	M. Dong

TECHNICAL DATA

Electrical

Impedance	50 Ω
Frequency range	0~40 GHz
VSWR	1.15:1
Contact resistance	
-centre contact	≤3mΩ
-outer contact	≤2mΩ
Insulation resistance	≥3000MΩ

Mechanical & Environmental

Durability (matings)	>500
Temperature range	-55 °C ~ +165 °C
RoHS Compliant	Yes

Material & Finish

Body	Stainless Steel (SU303), Passivated
Pin Contact	Beryllium Copper Alloy, Gold-plated
Insulator	PEI

Interface Standards

2.92mm	MIL-STD-348A
--------	--------------

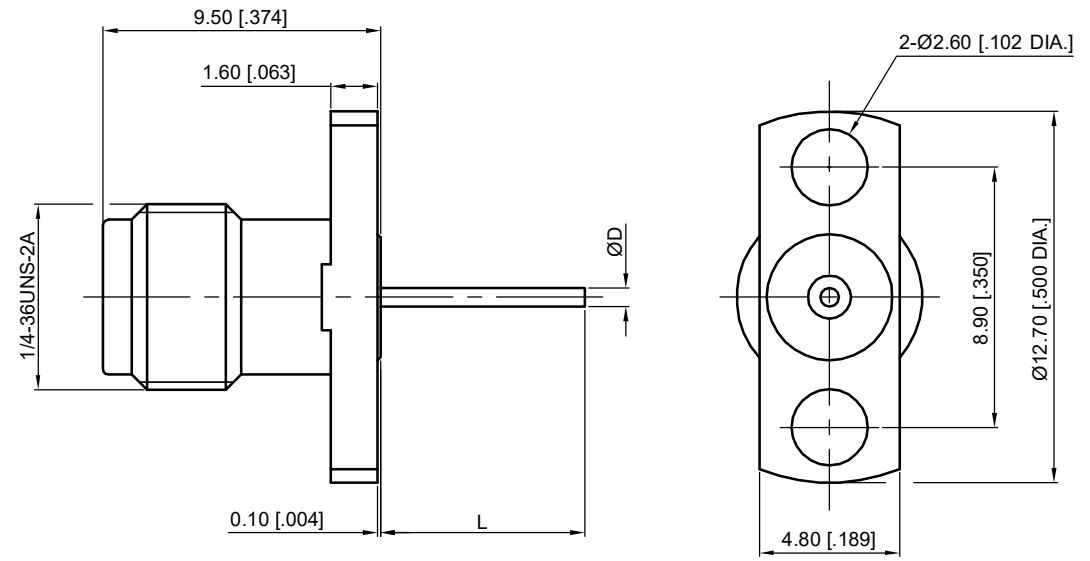

Part Number	ØD	L
96-02-9E2-029 A	0.64 [.025]	10.92 [.430]
96-02-9E2-029 B	0.64 [.025]	6.84 [.269]
96-02-9E2-029 C	0.30 [.012]	7 [.276]
96-02-9E2-029 D	0.75 [.030]	30 [1.181]

UNLESS OTHERWISE SPECIFIED, DIMENSIONS ARE IN MILLIMETERS (INCHES).
UNLESS OTHERWISE SPECIFIED DIMENSIONAL TOLERANCES ARE:

.XX	±0.13 [.005"]
.X	±0.20 [.008"]
X	±0.50 [.019"]

ANGULAR TOLERANCES ARE: ALL= ±1°

DO NOT SCALE DRAWING

PROJECTION:

DRAWN:	L. Ma	10/16/2016
CHECKED:	J. Zhu	10/16/2016
APPROVED:	M. Dong	10/16/2016

TITLE:
**2.92mm Straight Female,
Air Line Through the Wall,
2 Hole Flange**

CMPPTER[®]
Cmppter Electronics Co., Ltd. www.cmppter.com

PART No.:
96-02-9E2-029

SIZE: A4	SCALE: 4:1	SHEET: 1/1	REV: B
-------------	---------------	---------------	-----------

- NOTES:
- ALL SPECIFICATIONS ARE SUBJECT TO CHANGE WITHOUT NOTICE AT ANY TIME
 - UNLESS OTHERWISE SPECIFIED ALL DIMENSIONS ARE NOMINAL.