

REVISIONS				
REV	DESCRIPTION OF REVISION	ECN No.	DATE	APPROVED
A	INITIAL RELEASE	---	07/21/2012	M. Dong
B	ADD TYPE D	---	10/16/2016	M. Dong

### TECHNICAL DATA

#### Electrical

Impedance	50 Ω
Frequency range	0~40 GHz
VSWR	1.15:1
Contact resistance	
-centre contact	≤3mΩ
-outer contact	≤2mΩ
Insulation resistance	≥3000MΩ

#### Mechanical & Environmental

Durability (matings)	>500
Temperature range	-55 °C ~ +165 °C
RoHS Compliant	Yes

#### Material & Finish

Body	Stainless Steel (SU303), Passivated
Pin Contact	Beryllium Copper Alloy, Gold-plated
Insulator	PEI

#### Interface Standards

2.92mm	MIL-STD-348A
--------	--------------

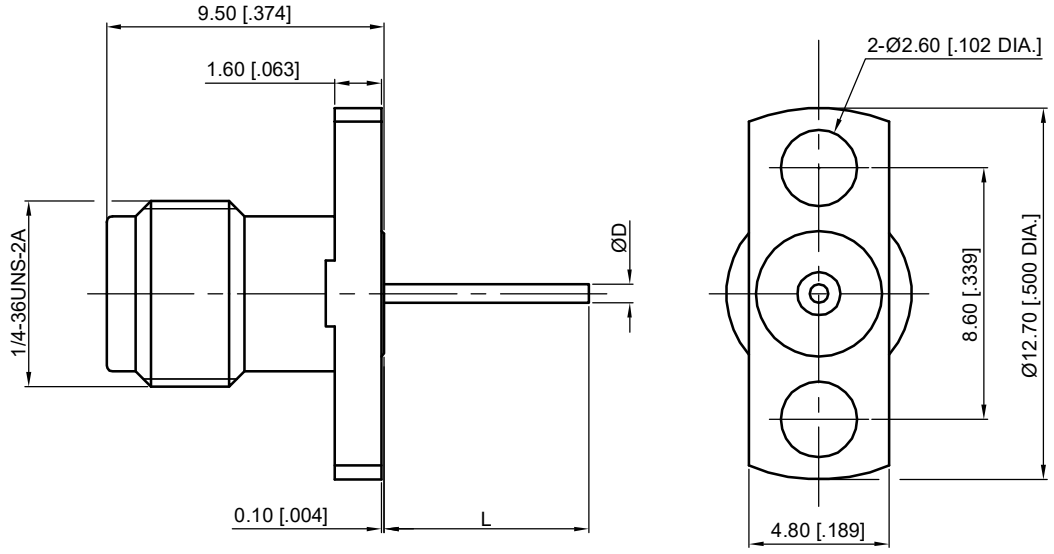

Part Number	ØD	L
96-02-9E2-030 A	0.64 [0.025]	10.92 [0.430]
96-02-9E2-030 B	0.64 [0.025]	6.84 [0.269]
96-02-9E2-030 C	0.30 [0.012]	7 [0.276]
96-02-9E2-030 D	0.75 [0.030]	30 [1.181]

UNLESS OTHERWISE SPECIFIED, DIMENSIONS ARE IN MILLIMETERS [INCHES]. UNLESS OTHERWISE SPECIFIED DIMENSIONAL TOLERANCES ARE: .XX ±0.13 [0.005"] .X ±0.20 [0.008"] X ±0.50 [0.019"]	
ANGULAR TOLERANCES ARE: ALL= ±1°	
DO NOT SCALE DRAWING	
PROJECTION:	

DRAWN:	L. Ma	10/16/2016
CHECKED:	J. Zhu	10/16/2016
APPROVED:	M. Dong	10/16/2016

TITLE:  
**2.92mm Straight Female,  
Air Line Through the Wall,  
2 Hole Flange**

**CMPPTER**<sup>®</sup>  
Cmppter Electronics Co., Ltd. [www.cmppter.com](http://www.cmppter.com)

PART No.:  
**96-02-9E2-030**

SIZE: A4	SCALE: 4:1	SHEET: 1/1	REV: B
-------------	---------------	---------------	-----------

- NOTES:
- ALL SPECIFICATIONS ARE SUBJECT TO CHANGE WITHOUT NOTICE AT ANY TIME
  - UNLESS OTHERWISE SPECIFIED ALL DIMENSIONS ARE NOMINAL.