

# TECHNICAL DATA

## Electrical

Impedance	50 Ω
Frequency range	0~40 GHz
VSWR	1.15:1
Contact resistance	
-centre contact	≤3mΩ
-outer contact	≤2mΩ
Insulation resistance	≥3000MΩ

## Mechanical & Environmental

Durability (matings)	>500
Temperature range	-55 °C ~ +165 °C
RoHS Compliant	Yes

## Material & Finish

Body	Stainless Steel (SU303), Passivated
Pin Contact	Beryllium Copper Alloy, Gold-plated
Insulator	PEI

## Interface Standards

2.92mm	MIL-STD-348A
--------	--------------

REVISIONS				
REV	DESCRIPTION OF REVISION	ECN No.	DATE	APPROVED
A	INITIAL RELEASE	—	07/21/2012	M. Dong
B	ADD TYPE D	—	10/16/2016	M. Dong

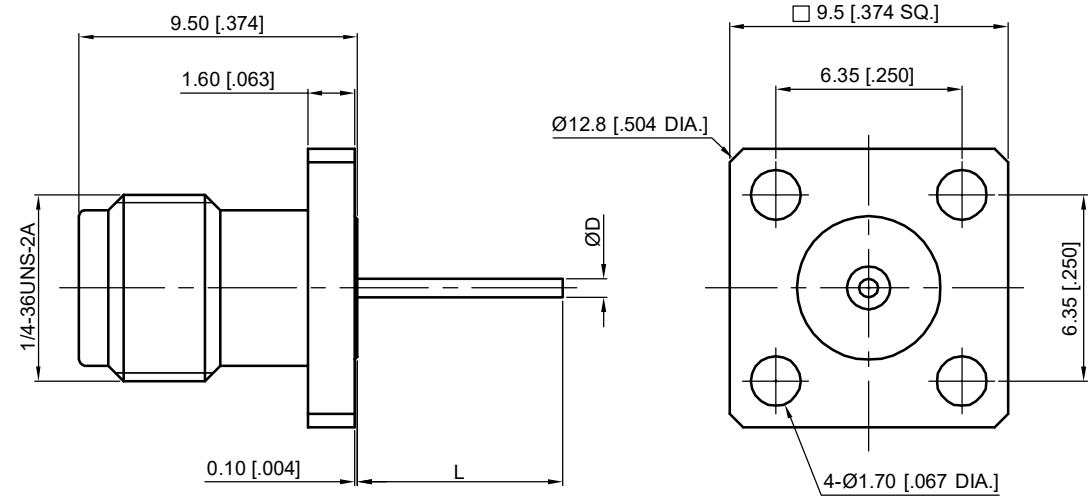

Part Number	ØD	L
96-02-9F2-026 A	0.64 [.025]	10.92 [.430]
96-02-9F2-026 B	0.64 [.025]	6.84 [.269]
96-02-9F2-026 C	0.30 [.012]	7 [.276]
96-02-9F2-026 D	0.75 [.030]	30 [1.181]

UNLESS OTHERWISE SPECIFIED, DIMENSIONS ARE IN MILLIMETERS (INCHES). UNLESS OTHERWISE SPECIFIED DIMENSIONAL TOLERANCES ARE: .XX ±0.13 [.005] .X ±0.20 [.008] X ±0.50 [.019] ANGULAR TOLERANCES ARE: ALL= ±1° DO NOT SCALE DRAWING PROJECTION:	
--	--

DRAWN:	L. Ma	10/16/2016
CHECKED:	J. Zhu	10/16/2016
APPROVED:	M. Dong	10/16/2016
TITLE: 2.92mm Straight Female, Air Line Through the Wall, 4 Hole Flange		

**CMPPTER**<sup>®</sup>  
 Cmppter Electronics Co., Ltd. [www.cmppter.com](http://www.cmppter.com)

PART No.:  
**96-02-9F2-026**

SIZE: A4	SCALE: 4:1	SHEET: 1/1	REV: B
-------------	---------------	---------------	-----------

NOTES:  
 1. ALL SPECIFICATIONS ARE SUBJECT TO CHANGE WITHOUT NOTICE AT ANY TIME  
 2. UNLESS OTHERWISE SPECIFIED ALL DIMENSIONS ARE NOMINAL.