

REV	DESCRIPTION OF REVISION	ECN No.	BY	DATE	APPROVED
A	INITIAL RELEASE	—	L. Ma	03/01/07	M. Dong
B	PART NUMBER CHANGED	—	L. Ma	07/05/09	M. Dong

## TECHNICAL DATA

### Electrical data

Impedance	50 Ω
Frequency range	0~4 GHz
Insulation resistance	≥5x10 <sup>3</sup> MΩ
Withstanding voltage	1000 V

### Mechanical data

Temperature range	-65 °C ~ +165 °C
Durability (matings)	>500

### Material data

Bodies	Brass, Nickel-plated
Pin Contact	Phosphor Bronze, Gold-plated
Insulator	PTFE
Crimp Ferrule	Copper, Nickel-plated
Gasket	Silicone Rubber

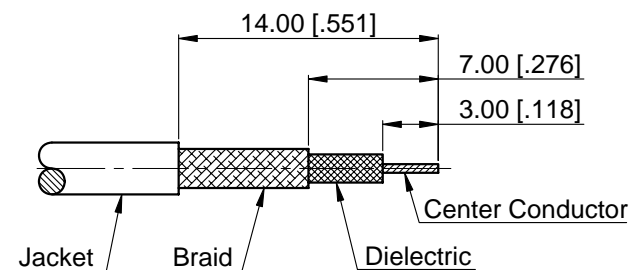

Cable Stripping Dimensions

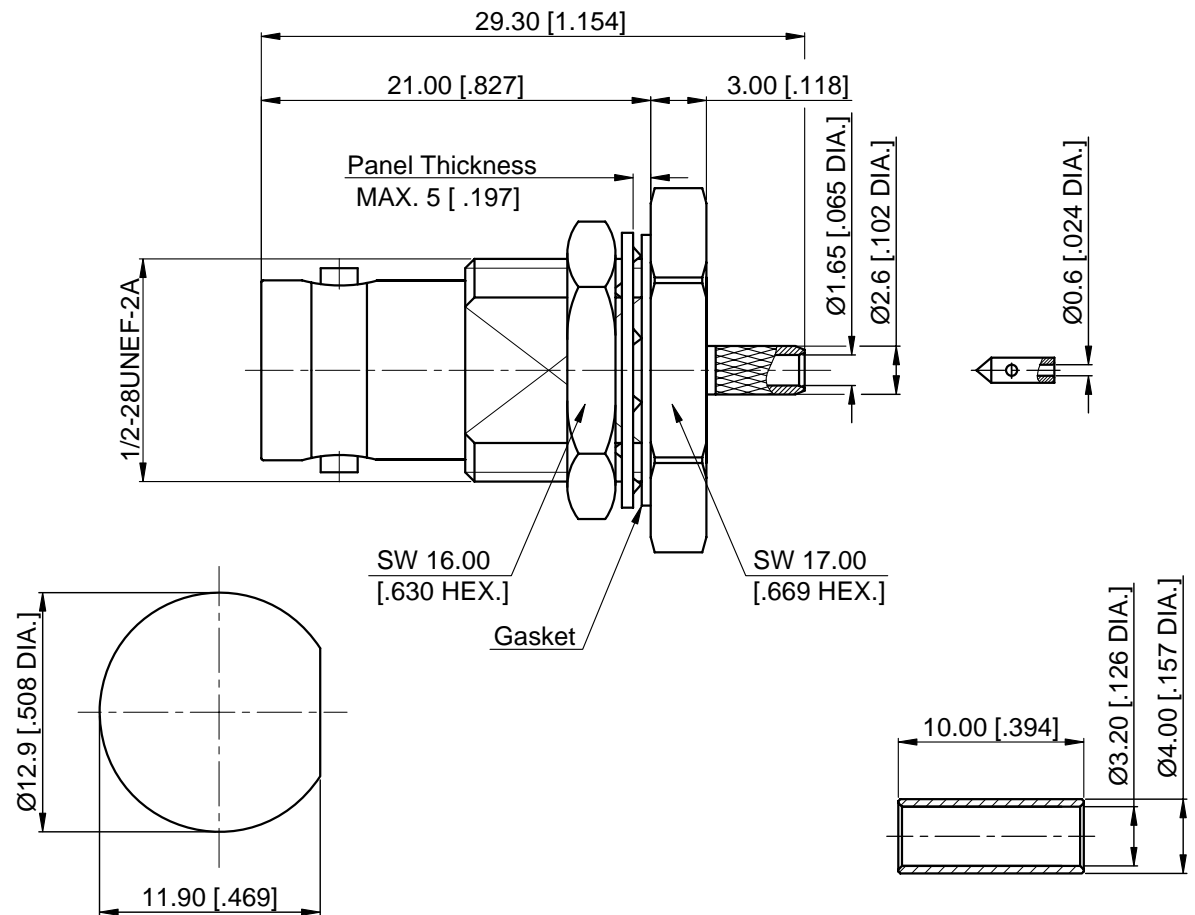

Recommended Mounting Hole

1. CRIMP FERRULE  
HEX.CRIMP TOOL SIZE: 3.25 [.128]

#### NOTES:

- ALL SPECIFICATIONS ARE SUBJECT TO CHANGE WITHOUT NOTICE AT ANY TIME
- CUSTOMER OUTLINE DRAWING FOR REFERENCE ONLY

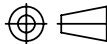
DRAWN: L. Ma 07/05/09 ENGINEER: J. Zhu 07/05/09 APPROVED: M. Dong 07/05/09 TOLERANCE UNLESS OTHERWISE SPECIFIED X ±0.50 [.019"] .X ±0.20 [.008"] .XX ±0.10 [.004"] ANGLES ±1°	TITLE: <b>BNC Straight Waterproof Bulkhead Female Crimp for LMR100/RG174/RG316 Cable</b>	 <a href="http://www.cmppter.com">www.cmppter.com</a>
PART No.: 10-02-1D00-023	 DIMENSIONS IN MILLIMETERS (mm)	SIZE: A4 SCALE: 2.5:1 SHEET: 1/1 REV: B