

TECHNICAL DATA

Electrical

Impedance	50 Ω
Frequency range	0~1 GHz
Withstanding voltage	1000 V
Insulation resistance	≥5000MΩ

Mechanical & Environmental

Durability (matings)	>500
Temperature range	-55 °C ~ +165 °C
RoHS Compliant	Yes

Material & Finish

Body	Brass, Nickel-plated
Pin Contact	Phosphor Bronze, Gold-plated
Crimp Ferrule	Copper, Nickel-plated
Insulator	PTFE
Gasket	Silicone Rubber

Interface Standards

BNC	IEC-60169
-----	-----------

REVISIONS				
REV	DESCRIPTION OF REVISION	ECN No.	DATE	APPROVED
A	INITIAL RELEASE	---	05/08/2014	M. Dong
B	SHOW PARTS DETAILS	---	05/06/2018	M. Dong

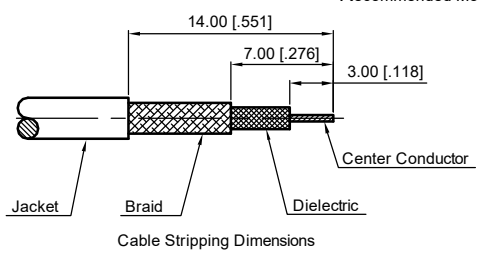
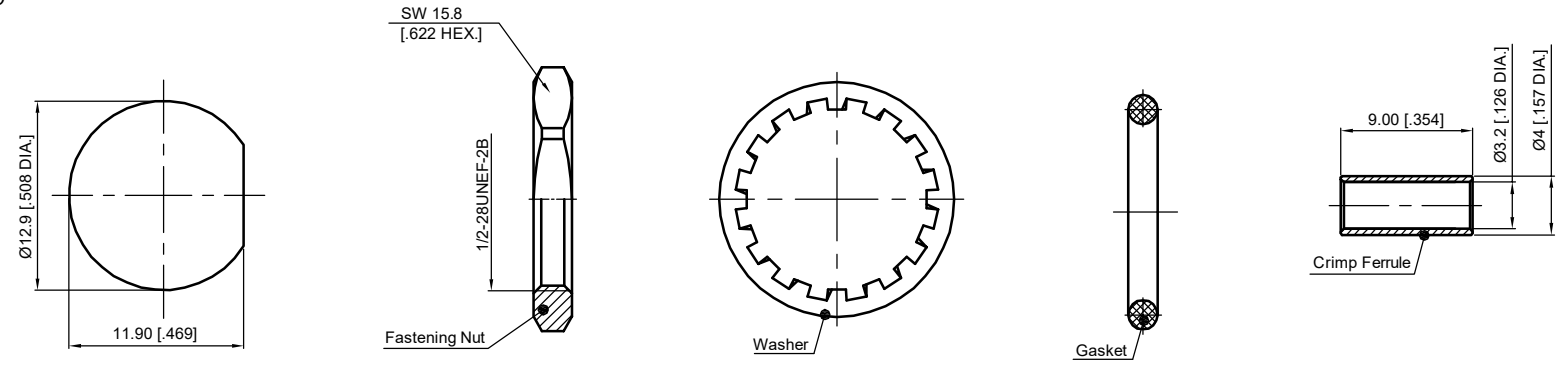
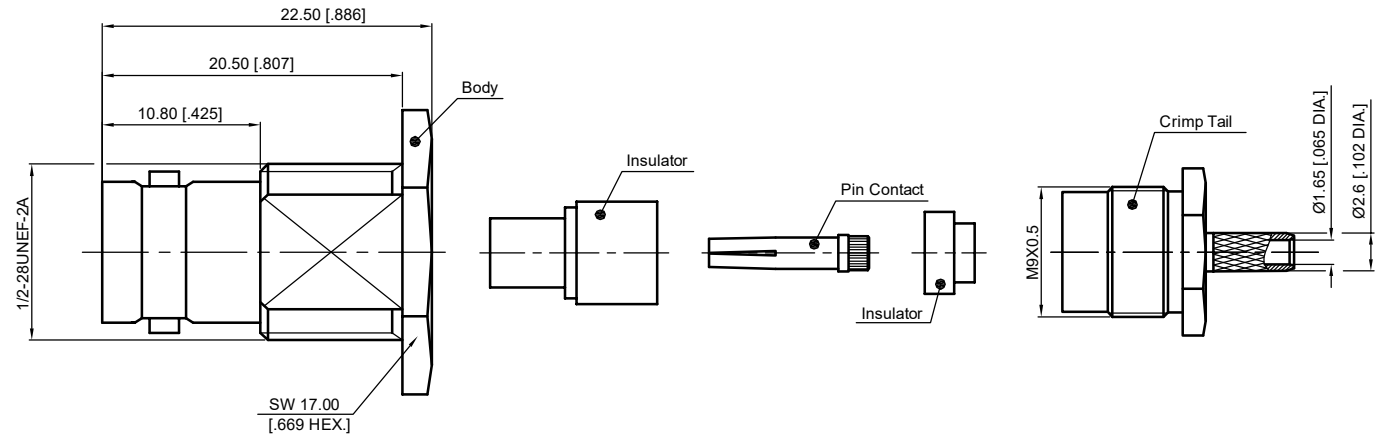

1. CRIMP FERRULE
HEX. CRIMP TOOL SIZE: 3.25 [.128]

- NOTES:
- ALL SPECIFICATIONS ARE SUBJECT TO CHANGE WITHOUT NOTICE AT ANY TIME
 - UNLESS OTHERWISE SPECIFIED ALL DIMENSIONS ARE NOMINAL.

UNLESS OTHERWISE SPECIFIED, DIMENSIONS ARE IN MILLIMETERS (INCHES)	
UNLESS OTHERWISE SPECIFIED DIMENSIONAL TOLERANCES ARE:	
.XX	±0.13 [.005"]
X	±0.20 [.008"]
X	±0.50 [.019"]
ANGULAR TOLERANCES ARE: ALL= ±1°	
DO NOT SCALE DRAWING	
PROJECTION:	

DRAWN:	L. Ma	05/06/2018
CHECKED:	J. Zhu	05/06/2018
APPROVED:	M. Dong	05/06/2018

TITLE:
BNC Straight Waterproof
Bulkhead Female Crimp for
LMR100/RG174/RG316 Cable

CMPPTER[®]
Cmppter Electronics Co., Ltd. www.cmppter.com

PART No.:
10-02-1D00-058

SIZE: A4	SCALE: 2:1	SHEET: 1/1	REV: B
-------------	---------------	---------------	-----------