

TECHNICAL DATA

Electrical

Impedance	50 Ω
Frequency range	0~ 1 GHz
Voltage Rating	1000 Vrms
Insulation resistance	≥5000MΩ

Mechanical & Environmental

Durability (matings)	>500
Temperature range	-55 °C ~ +165 °C
RoHS Compliant	Yes

Material & Finish

Body	Brass, Nickel-plated
Pin Contact	Brass, Gold-plated
Insulator	PTFE

Interface Standards

BNC	IEC-60169
-----	-----------

REVISIONS				
REV	DESCRIPTION OF REVISION	ECN No.	DATE	APPROVED
A	INITIAL RELEASE	—	10/31/2017	M. Dong

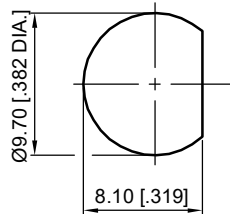
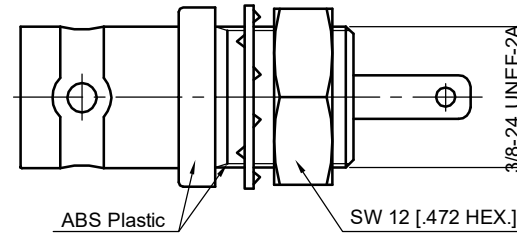
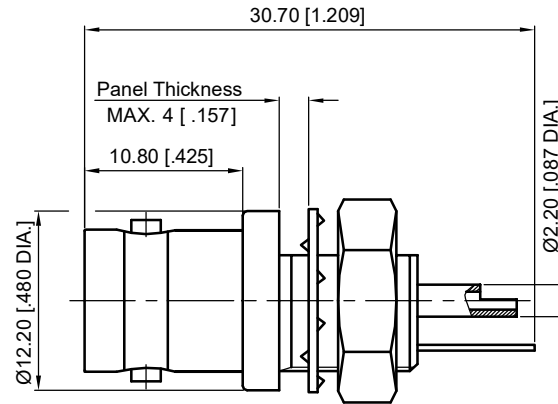

Recommended Mounting Hole

NOTES:

- ALL SPECIFICATIONS ARE SUBJECT TO CHANGE WITHOUT NOTICE AT ANY TIME
- UNLESS OTHERWISE SPECIFIED ALL DIMENSIONS ARE NOMINAL.

UNLESS OTHERWISE SPECIFIED, DIMENSIONS ARE IN MILLIMETERS (INCHES).
UNLESS OTHERWISE SPECIFIED DIMENSIONAL TOLERANCES ARE:

.XX	±0.13 [.005"]
.X	±0.20 [.008"]
X	±0.50 [.019"]

ANGULAR TOLERANCES ARE: ALL= ±1°

DO NOT SCALE DRAWING

PROJECTION:

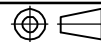

DRAWN:	L. Ma	10/31/2017
CHECKED:	J. Zhu	10/31/2017
APPROVED:	M. Dong	10/31/2017

TITLE:
BNC Bulkhead Female Isolated
Ground with Solder Cup Terminal



Cmpter Electronics Co., Ltd. www.cmpter.com

PART No.:
10-02-8A1-080

SIZE: A4	SCALE: 2:1	SHEET: 1/1	REV: A
-------------	---------------	---------------	-----------