

REVISIONS

REV	DESCRIPTION OF REVISION	ECN No.	DATE	APPROVED
A	INITIAL RELEASE	—	05/08/2018	M. Dong

**TECHNICAL DATA**

**Electrical**

Impedance 50 Ω  
 Frequency range 0~ 3 GHz  
 Withstanding voltage 1000 V  
 Insulation resistance ≥5000MΩ

**Mechanical & Environmental**

Durability (matings) >500  
 Temperature range -55 °C ~ +165 °C  
 RoHS Compliant Yes

**Material & Finish**

Body Brass, Nickel-plated  
 Pin Contact Brass, Gold-plated  
 Coupling Nut Brass, Nickel-plated  
 Ferrule Copper, Nickel-plated  
 Insulator PTFE  
 Gasket Silicone Rubber

**Interface Standards**

BNC IEC-60169

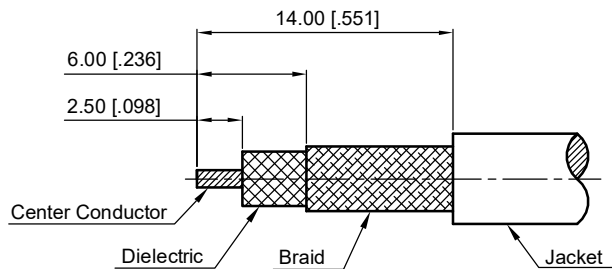
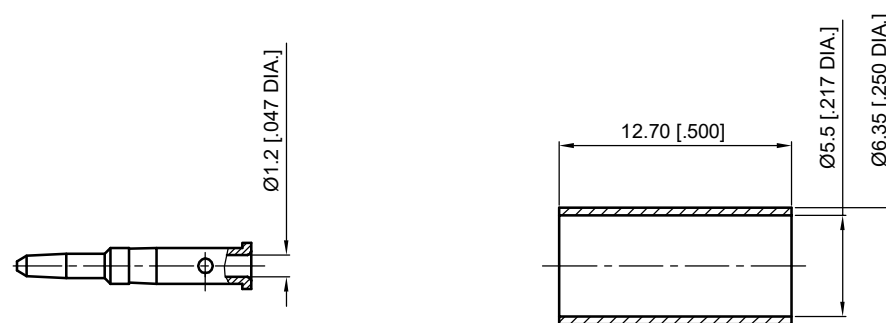
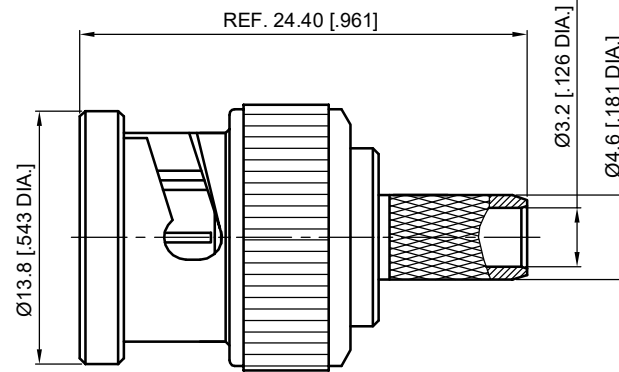

Cable Stripping Dimensions

1.CRIMP FERRULE  
 HEX. CRIMP TOOL SIZE : 5.4 [.213]

- NOTES:
- ALL SPECIFICATIONS ARE SUBJECT TO CHANGE WITHOUT NOTICE AT ANY TIME
  - UNLESS OTHERWISE SPECIFIED ALL DIMENSIONS ARE NOMINAL.

UNLESS OTHERWISE SPECIFIED, DIMENSIONS ARE IN MILLIMETERS (INCHES).  
 UNLESS OTHERWISE SPECIFIED DIMENSIONAL TOLERANCES ARE:

.XX ±0.13 [.005"]  
 X ±0.20 [.008"]  
 X ±0.50 [.019"]

ANGULAR TOLERANCES ARE: ALL= ±1°

DO NOT SCALE DRAWING

PROJECTION:

DRAWN:	L. Ma	05/08/2018
CHECKED:	J. Zhu	05/08/2018
APPROVED:	M. Dong	05/08/2018

TITLE:  
**BNC Striaght Male Crimp for LMR200 Cable**



Cmpter Electronics Co., Ltd. [www.cmpter.com](http://www.cmpter.com)

PART No.:  
**10-03-1M17-087**

SIZE:	SCALE:	SHEET:	REV:
A4	2.5:1	1/1	A