

TECHNICAL DATA

Electrical

Impedance	50 Ω
Frequency range	0~3 GHz
Voltage Rating	250 V rms
Insulation resistance	≥1000MΩ

Mechanical & Environmental

Durability (matings)	>500
Temperature range	-55 °C ~ +165 °C
RoHS Compliant	Yes

Material & Finish

Body	Brass, Gold-plated
Pin Contact	Beryllium Copper Alloy, Gold-plated
Fastening Nut	Brass, Gold-plated
Sleeve	Brass, Gold-plated
Inner Ferrule	Brass, Gold-plated
Insulator	PTFE

Interface Standards

MCX	IEC-61169
-----	-----------

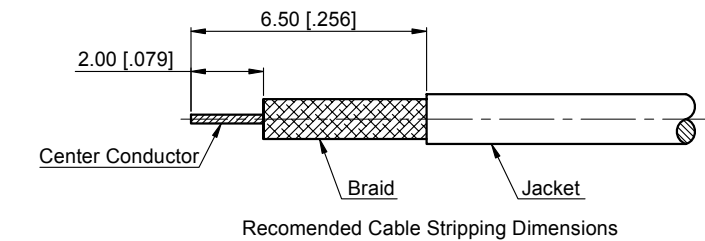
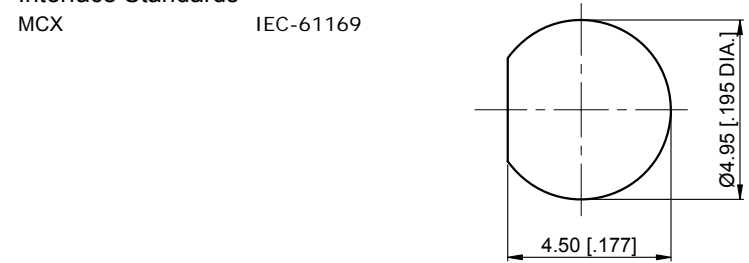

NOTES:

- ALL SPECIFICATIONS ARE SUBJECT TO CHANGE WITHOUT NOTICE AT ANY TIME
- UNLESS OTHERWISE SPECIFIED ALL DIMENSIONS ARE NOMINAL.

REVISIONS				
REV	DESCRIPTION OF REVISION	ECN No.	DATE	APPROVED
A	INITIAL RELEASE	---	02/05/2015	M. Dong
B	SCREW THREAD CHANGED	---	03/01/2015	M. Dong

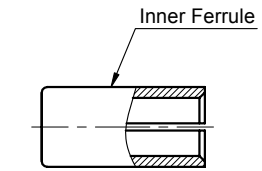
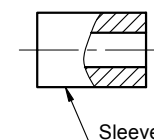
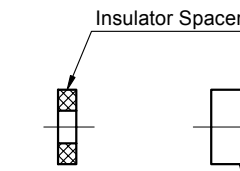
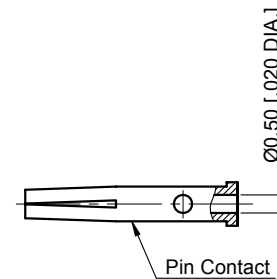
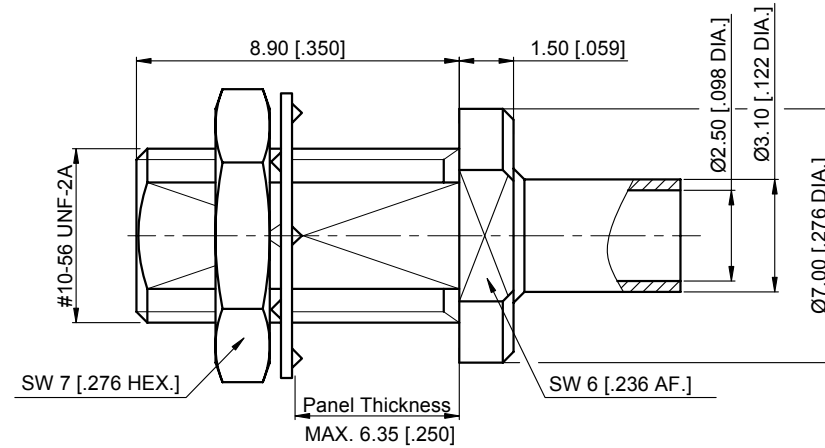

1. CRIMP FERRULE
HEX. CRIMP TOOL SIZE: 2.7 [0.106]

UNLESS OTHERWISE SPECIFIED, DIMENSIONS ARE IN MILLIMETERS (INCHES).
UNLESS OTHERWISE SPECIFIED DIMENSIONAL TOLERANCES ARE:

.XX	±0.13 [0.005"]
.X	±0.20 [0.008"]
X	±0.50 [0.019"]

ANGULAR TOLERANCES ARE: ALL ±1°

DO NOT SCALE DRAWING

PROJECTION:

DRAWN:	L. Ma	03/01/2015
CHECKED:	J. Zhu	03/01/2015
APPROVED:	M. Dong	03/01/2015

TITLE:

MCX Straight Bulkhead Female Crimp for 1.37mm Cable



Cmptter Electronics Co., Ltd. www.cmptter.com

PART No.:
30-02-1B23-030

SIZE:	SCALE:	SHEET:	REV:
A4	5:1	1/1	B