

TECHNICAL DATA

Electrical

Impedance	75 Ω
Frequency range	0~1 GHz
Working voltage	1000 Vrms
Insulation resistance	≥5000MΩ

Mechanical & Environmental

Durability (matings)	>500
Temperature range	-55 °C ~ +165 °C
RoHS Compliant	Yes

Material & Finish

Body	Brass, Nickel-plated
Pin Contact	Phosphor Bronze, Gold-plated
Fastening Nut	Brass, Nickel-plated
Crimp Ferrule	Copper, Nickel-plated
Insulator	PTFE
Gasket	Silicone Rubber

Interface Standards

N	IEC-60169
---	-----------

REVISIONS				
REV	DESCRIPTION OF REVISION	ECN No.	DATE	APPROVED
A	INITIAL RELEASE		02/14/2017	M. Dong

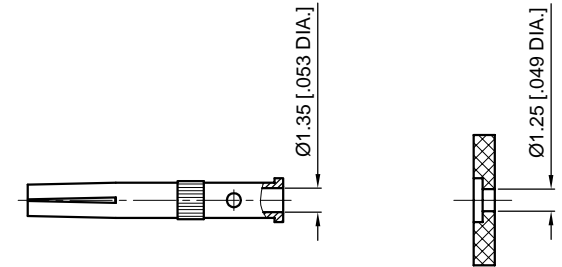
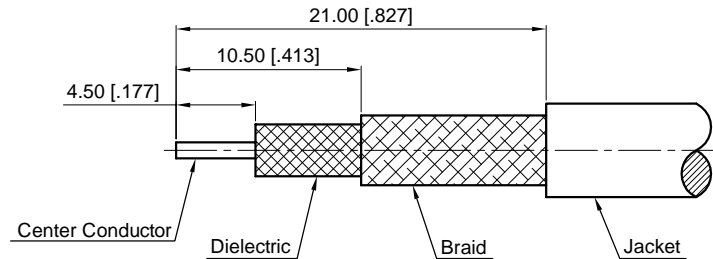
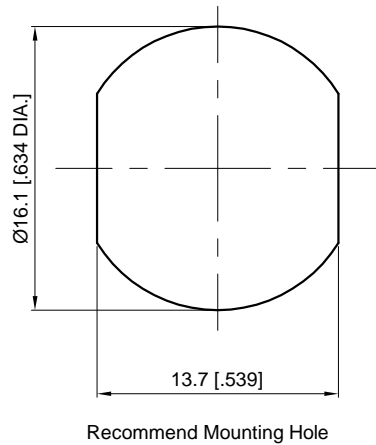
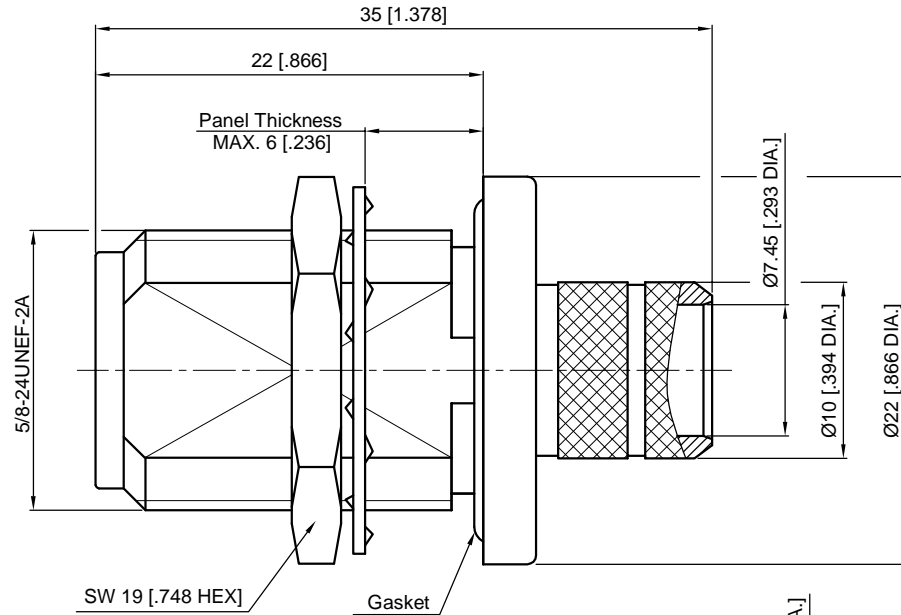

- NOTES:
- ALL SPECIFICATIONS ARE SUBJECT TO CHANGE WITHOUT NOTICE AT ANY TIME
 - UNLESS OTHERWISE SPECIFIED ALL DIMENSIONS ARE NOMINAL.

UNLESS OTHERWISE SPECIFIED, DIMENSIONS ARE IN MILLIMETERS [INCHES]. UNLESS OTHERWISE SPECIFIED DIMENSIONAL TOLERANCES ARE: .XX ±0.13 [.005"] X ±0.20 [.008"] X ±0.50 [.019"] ANGULAR TOLERANCES ARE: ALL= ±1° DO NOT SCALE DRAWING PROJECTION:	DRAWN: L. Ma 02/14/2017 CHECKED: J. Zhu 02/14/2017 APPROVED: M. Dong 02/14/2017 TITLE: 75 Ohm N Straight Waterproof Bulkhead Female Crimp for RG11 Cable
---	--

75 Ohm N Straight Waterproof Bulkhead Female Crimp for RG11 Cable

CMPPTER [®]			
Cmppter Electronics Co., Ltd. www.cmppter.com			
PART No.:			
50-02-1D07-177			
SIZE: A4	SCALE: 2.5:1	SHEET: 1/1	REV: A