

TECHNICAL DATA

Electrical
 Impedance 50 Ω
 Frequency range 0~1 GHz
 Insulation resistance ≥5x10³ MΩ
 Withstanding voltage 1000 V

Mechanical & Environmental
 Durability (matings) >500
 Temperature range -55 °C ~ +165 °C
 RoHS Compliant Yes

Material & Finish
 Body Brass, Nickel-plated
 Pin Contact Phosphor Bronze, Gold-plated
 Fastening Nut Brass, Nickel-plated
 Insulator PTFE
 Gasket Silicone Rubber

Interface Standards
 N IEC-60169

REVISIONS				
REV	DESCRIPTION OF REVISION	ECN No.	DATE	APPROVED
A	INITIAL RELEASE		03/28/2015	M. Dong

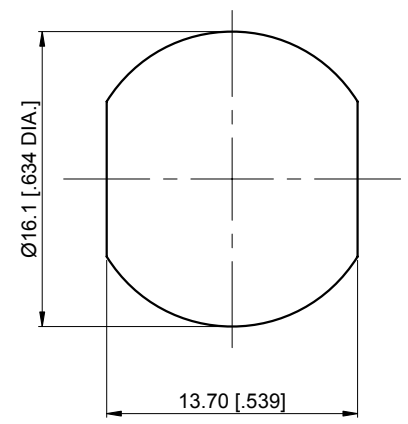
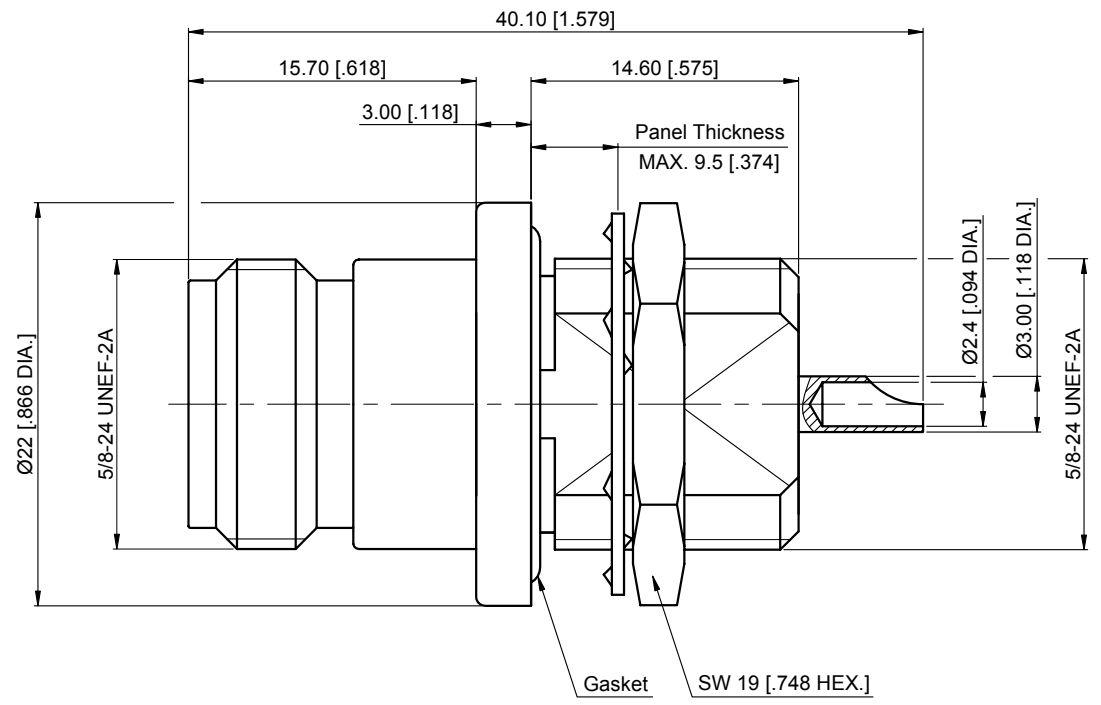

Recommend Mounting Hole

UNLESS OTHERWISE SPECIFIED, DIMENSIONS ARE IN MILLIMETERS [INCHES].
 UNLESS OTHERWISE SPECIFIED DIMENSIONAL TOLERANCES ARE:
 .XX ±0.13 [.005"]
 X ±0.20 [.008"]
 X ±0.50 [.019"]
 ANGULAR TOLERANCES ARE: ALL=±1°
 DO NOT SCALE DRAWING
 PROJECTION:

DRAWN:	L. Ma	03/28/2015
CHECKED:	J. Zhu	03/28/2015
APPROVED:	M. Dong	03/28/2015

TITLE:
N Straight Waterproof Bulkhead Female with Solder Cup

CMPPTER[®]
 Cmptter Electronics Co., Ltd. www.cmptter.com
 PART No.:
50-02-8C1-139
 SIZE: A4 SCALE: 2.5:1 SHEET: 1/1 REV: A

- NOTES:
 1. ALL SPECIFICATIONS ARE SUBJECT TO CHANGE WITHOUT NOTICE AT ANY TIME
 2. UNLESS OTHERWISE SPECIFIED ALL DIMENSIONS ARE NOMINAL.