

TECHNICAL DATA

Electrical

Impedance	50 Ω
Frequency range	0~6 GHz
Withstanding voltage	500 V
Insulation resistance	≥5000MΩ

Mechanical & Environmental

Durability (matings)	>500
Temperature range	-55 °C ~ +165 °C
RoHS Compliant	Yes

Material & Finish

Body	Brass, Gold-plated
Pin Contact	Beryllium Copper Alloy, Gold-plated
Fastening Nut	Brass, Gold-plated
Washer	Phosphor Bronze, Gold-plated
Insulator	PTFE
Gasket	Silicone Rubber

Interface Standards

SMA	IEC-60169
-----	-----------

REVISIONS				
REV	DESCRIPTION OF REVISION	ECN No.	DATE	APPROVED
A	INITIAL RELEASE	—	01/15/2019	M. Dong

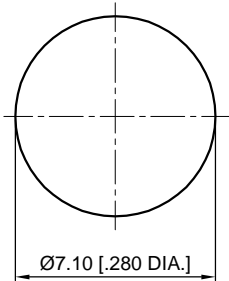
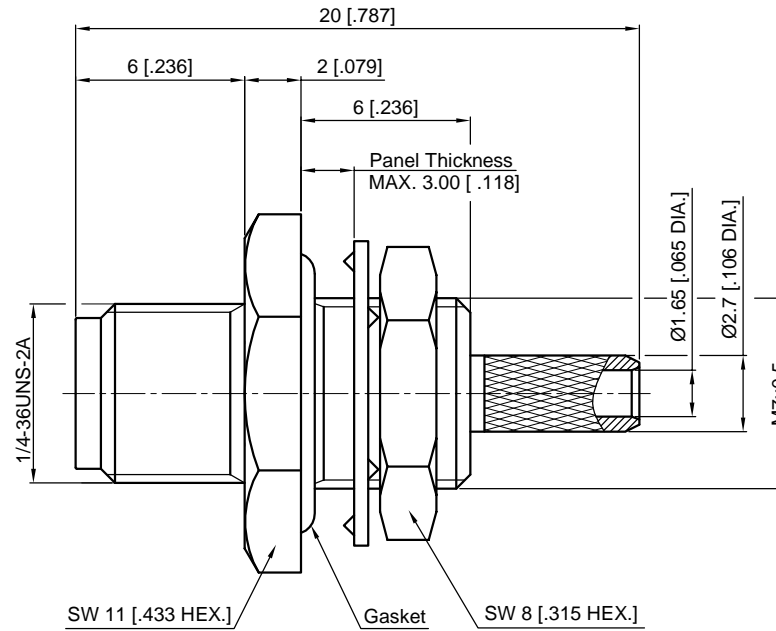

Recommended Mounting Hole

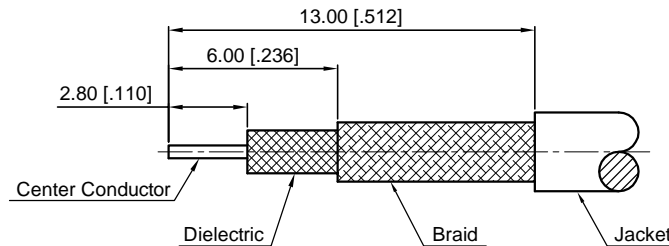

Recommended Cable Stripping Dimensions

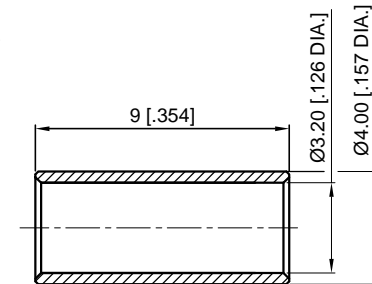

1. CRIMP FERRULE
HEX. CRIMP TOOL SIZE: 3.25 [.128]

NOTES:

- ALL SPECIFICATIONS ARE SUBJECT TO CHANGE WITHOUT NOTICE AT ANY TIME
- UNLESS OTHERWISE SPECIFIED ALL DIMENSIONS ARE NOMINAL.

UNLESS OTHERWISE SPECIFIED, DIMENSIONS ARE IN MILLIMETERS (INCHES). UNLESS OTHERWISE SPECIFIED DIMENSIONAL TOLERANCES ARE: .XX ±0.13 [.005"] X ±0.20 [.008"] X ±0.50 [.019"] ANGULAR TOLERANCES ARE: ALL= ±1° DO NOT SCALE DRAWING PROJECTION:	
---	--

DRAWN:	L. Ma	01/15/2019
CHECKED:	J. Zhu	01/15/2019
APPROVED:	M. Dong	01/15/2019

TITLE:
SMA Straight Waterproof Bulkhead Female Crimp for LMR100/RG174/RG316 Cable

CMPPTER [®]			
Cmptter Electronics Co., Ltd. www.cmptter.com			
PART No.:			
60-02-1C00-328			
SIZE:	SCALE:	SHEET:	REV:
A4	4:1	1/1	A