

REVISIONS				
REV	DESCRIPTION OF REVISION	ECN No.	DATE	APPROVED
A	INITIAL RELEASE		11/13/2014	M. Dong

TECHNICAL DATA

Electrical

Impedance 50 Ω
 Frequency range 0~6 GHz
 Withstanding voltage 500 V
 Insulation resistance ≥500MΩ

Mechanical & Environmental

Durability (matings) >500
 Temperature range -55 °C ~ +165 °C
 RoHS Compliant Yes

Material & Finish

Body Brass, Gold-plated
 Pin Contact Beryllium Copper Alloy, Gold-plated
 Fastening Nut Brass, Gold-plated
 Insulator PTFE

Interface Standards

SMA IEC-60169

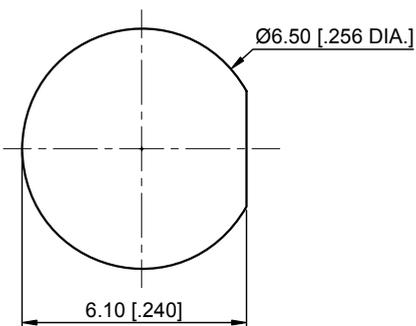
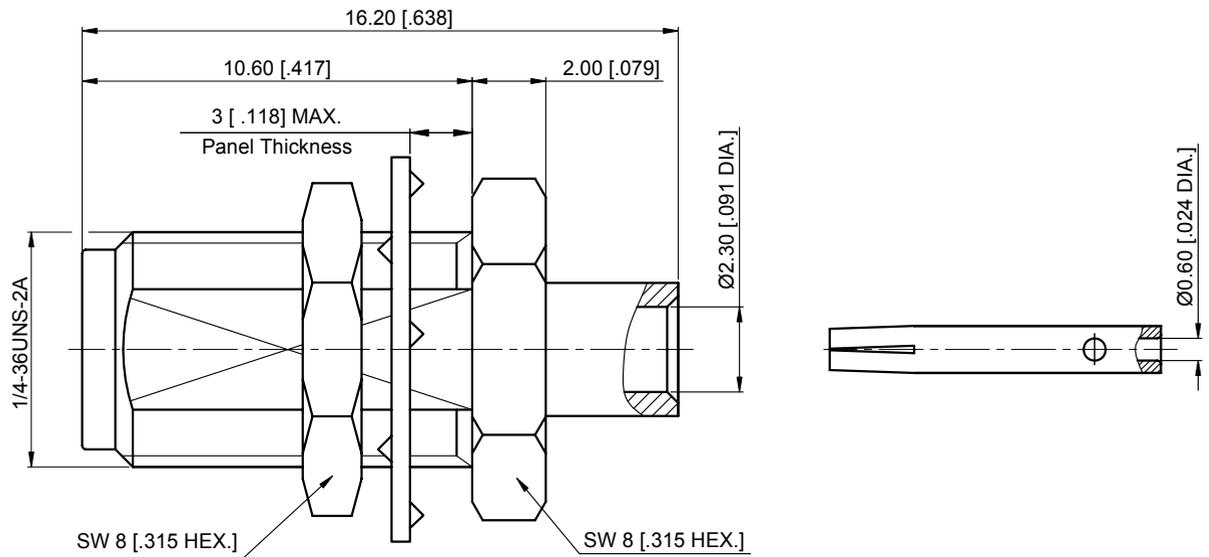

Recommended Mounting Hole

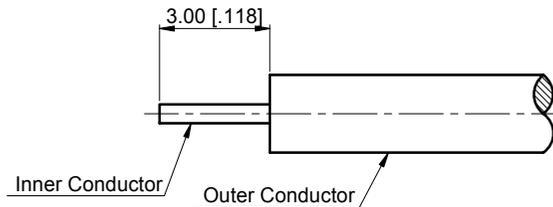

CABLE STRIPPING DIMENSION

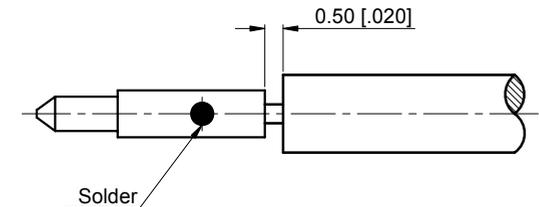

PIN CONTACT SOLDERING DIMENSION

NOTES:

- ALL SPECIFICATIONS ARE SUBJECT TO CHANGE WITHOUT NOTICE AT ANY TIME
- UNLESS OTHERWISE SPECIFIED ALL DIMENSIONS ARE NOMINAL.

UNLESS OTHERWISE SPECIFIED, DIMENSIONS ARE IN MILLIMETERS [INCHES]. UNLESS OTHERWISE SPECIFIED DIMENSIONAL TOLERANCES ARE: .XX ±0.13 [0.005"] X ±0.20 [0.008"] X ±0.50 [0.019"] ANGULAR TOLERANCES ARE: ALL±1°
DO NOT SCALE DRAWING
PROJECTION:

DRAWN:	L. Ma	11/13/2014
CHECKED:	J. Zhu	11/13/2014
APPROVED:	M. Dong	11/13/2014

TITLE:
SMA Bulkhead Female Solder for RG405/.086 Cable

CMPPTER [®]			
Cmptter Electronics Co., Ltd. www.cmptter.com			
PART No.: 60-02-2B11-195			
SIZE: A4	SCALE: 5:1	SHEET: 1/1	REV: A