

TECHNICAL DATA

Electrical

Impedance	50 Ω
Frequency range	0~6 GHz
Withstanding voltage	1000 V
Insulation resistance	≥5000MΩ

Mechanical & Environmental

Durability (matings)	>500
Temperature range	-55 °C ~ +165 °C
RoHS Compliant	Yes

Material & Finish

Body	Brass, See Schedule
Pin Contact	Brass, Gold-plated
Coupling Nut	Brass, See Schedule
Crimp Ferrule	Copper, Nickel -plated
Insulator	PTFE
Gasket	Silicone rubber

Interface Standards

SMA	IEC-60169
-----	-----------

REVISIONS				
REV	DESCRIPTION OF REVISION	ECN No.	DATE	APPROVED
A	INITIAL RELEASE	---	03/12/2007	M. Dong
B	STRUCTURE CHANGED	---	01/18/2010	M. Dong
C	STRUCTURE CHANGED	---	08/25/2014	M. Dong
D	STRUCTURE CHANGED	---	03/16/2016	M. Dong
E	STRUCTURE CHANGED	---	09/25/2018	M. Dong

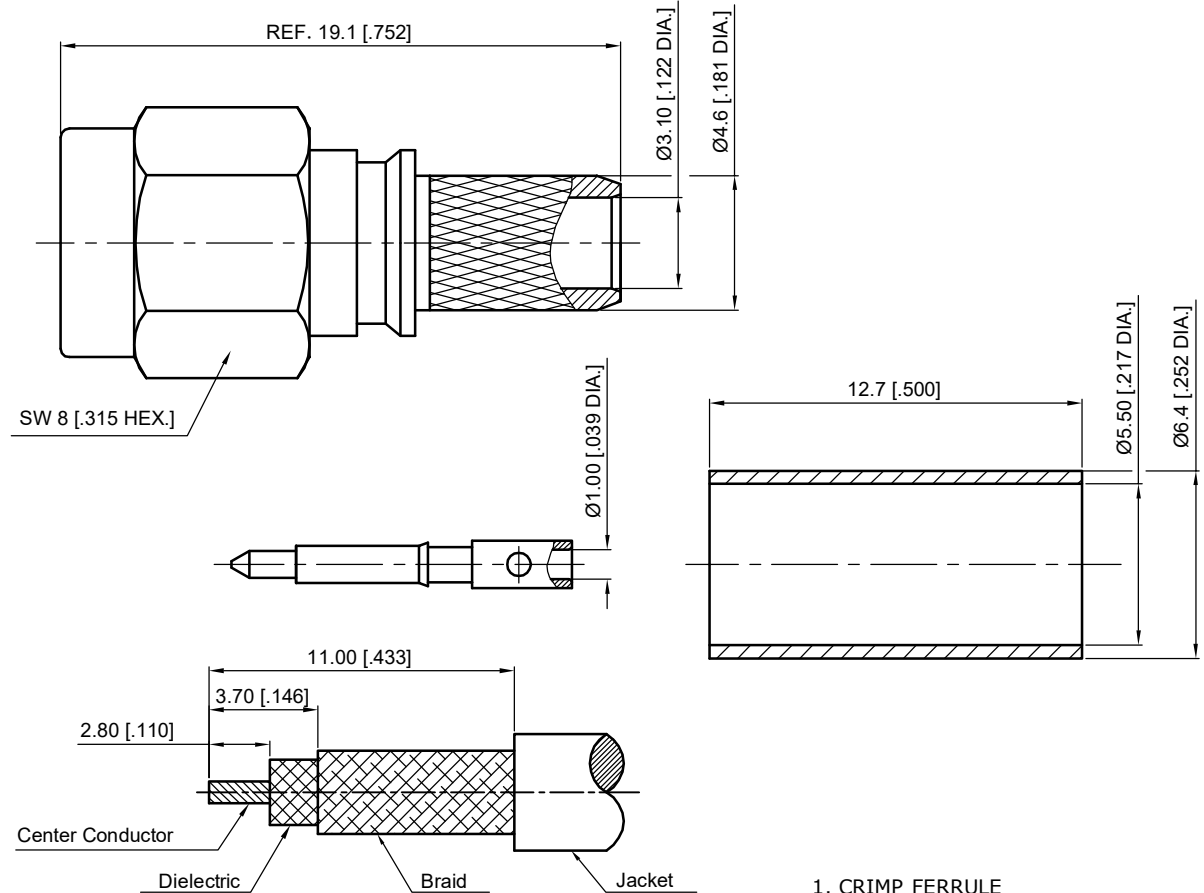

Recommended Cable Stripping Dimensions

1. CRIMP FERRULE
HEX. CRIMP TOOL SIZE: 5.4 [.213]

Part Number	Part / Finish
60-03-1M18-004-1	Bodies / Gold
	Coupling Nut / Gold
60-03-1M18-004-2	Bodies / Nickel
	Coupling Nut / Nickel

UNLESS OTHERWISE SPECIFIED, DIMENSIONS ARE IN MILLIMETERS [INCHES]. UNLESS OTHERWISE SPECIFIED DIMENSIONAL TOLERANCES ARE: .XX ±0.13 [.005"] .X ±0.20 [.008"] X ±0.50 [.019"] ANGULAR TOLERANCES ARE: ALL= ±1° DO NOT SCALE DRAWING PROJECTION:
--

DRAWN:	L. Ma	09/25/2018
CHECKED:	J. Zhu	09/25/2018
APPROVED:	M. Dong	09/25/2018

TITLE:
SMA Straight Male Crimp for LMR195/RG58 Cable

CMP TER[®]
Cmpter Electronics Co., Ltd. www.cmpter.com

PART No.:
60-03-1M18-004

SIZE: A4	SCALE: 4:1	SHEET: 1/1	REV: E
----------	------------	------------	--------

NOTES:
1. ALL SPECIFICATIONS ARE SUBJECT TO CHANGE WITHOUT NOTICE AT ANY TIME
2. UNLESS OTHERWISE SPECIFIED ALL DIMENSIONS ARE NOMINAL.