

# TECHNICAL DATA

## Electrical

Impedance	50 Ω
Frequency range	0~6 GHz
Withstanding voltage	500 V
Insulation resistance	≥5000MΩ

## Mechanical & Environmental

Durability (matings)	>500
Temperature range	-55 °C ~ +165 °C
RoHS Compliant	Yes

## Material & Finish

Body	Brass, Gold-plated
Pin Contact	Beryllium Copper Alloy, Gold-plated
Fastening Nut	Brass, Gold-plated
Washer	Phosphor Bronze, Gold-plated
Insulator	PTFE
Gasket	Silicone Rubber

## Interface Standards

SMA	IEC-60169
-----	-----------

REVISIONS				
REV	DESCRIPTION OF REVISION	ECN No.	DATE	APPROVED
A	INITIAL RELEASE	---	03/30/2015	M. Dong
B	DIMENSIONS CHANGED	---	03/12/2019	M. Dong

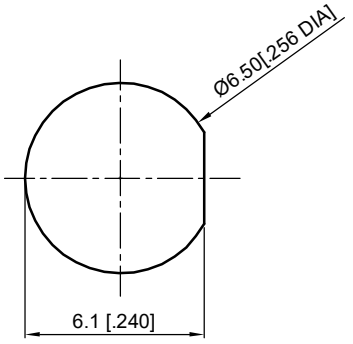
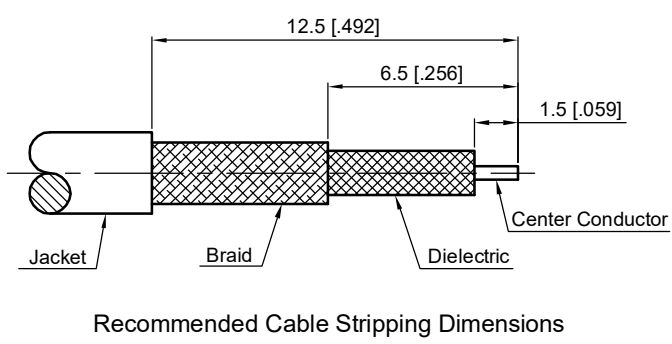
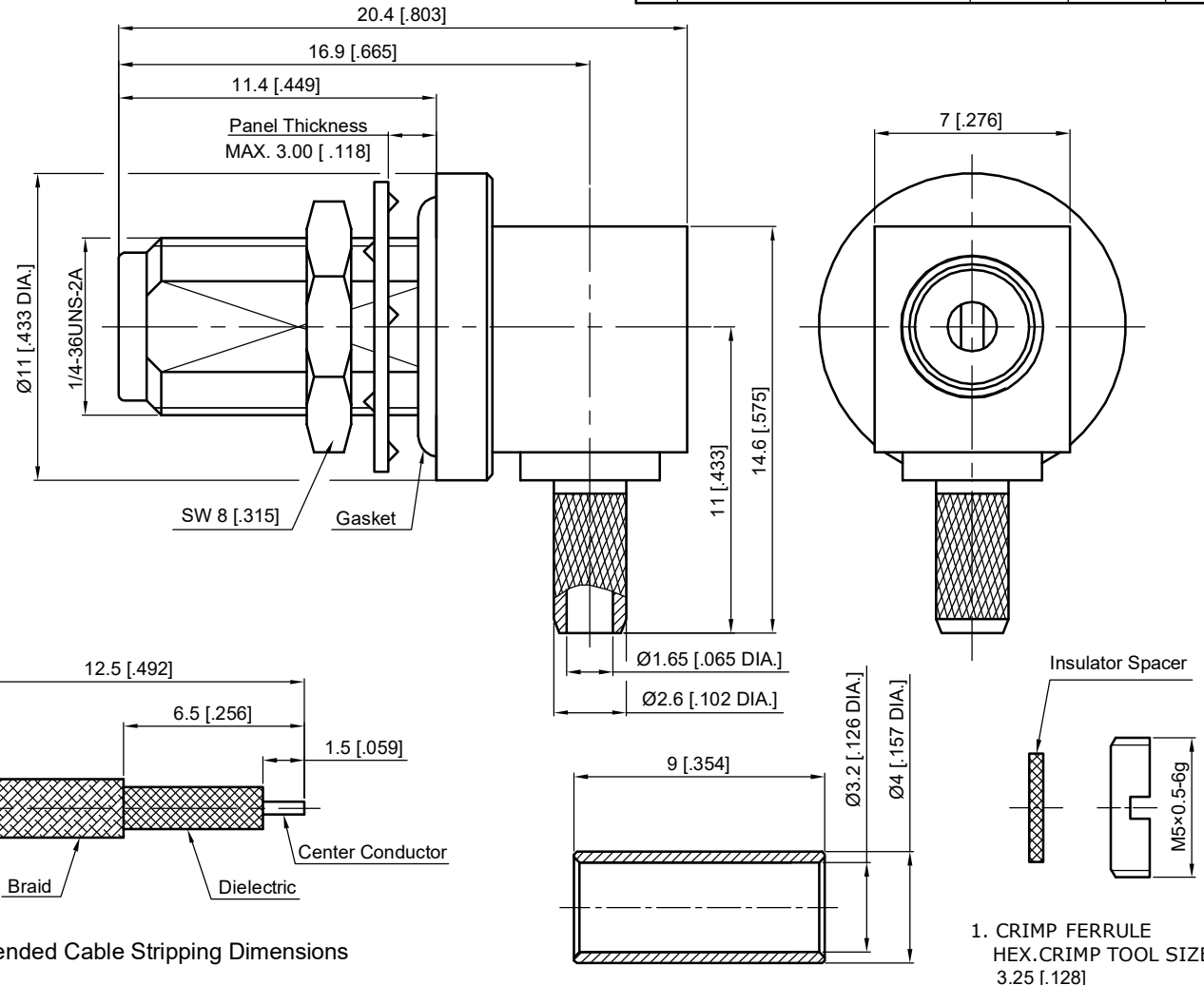

1. CRIMP FERRULE  
HEX. CRIMP TOOL SIZE:  
3.25 [128]

## Recommended Mounting Hole

- NOTES:
- ALL SPECIFICATIONS ARE SUBJECT TO CHANGE WITHOUT NOTICE AT ANY TIME
  - UNLESS OTHERWISE SPECIFIED ALL DIMENSIONS ARE NOMINAL.

UNLESS OTHERWISE SPECIFIED, DIMENSIONS ARE IN MILLIMETERS [INCHES].  
UNLESS OTHERWISE SPECIFIED DIMENSIONAL TOLERANCES ARE:

.XX	±0.13 [0.005"]
.X	±0.20 [0.008"]
X	±0.50 [0.019"]

ANGULAR TOLERANCES ARE: ALL= ±1°

DO NOT SCALE DRAWING

PROJECTION:

DRAWN:	L. Ma	03/12/2019
CHECKED:	J. Zhu	03/12/2019
APPROVED:	M. Dong	03/12/2019

TITLE:  
SMA Right Angle Waterproof  
Bulkhead Female Crimp for  
RG174/RG316/LMR100 Cable

**CMPPTER**<sup>®</sup>  
Cmppter Electronics Co., Ltd. [www.cmppter.com](http://www.cmppter.com)

PART No.:  
**60-12-1D00-207**

SIZE: A4	SCALE: 4:1	SHEET: 1/1	REV: B
-------------	---------------	---------------	-----------