

# TECHNICAL DATA

## Electrical

Impedance	50 Ω
Frequency range	0~6 GHz
Withstanding voltage	500 V
Insulation resistance	≥5000MΩ

## Mechanical & Environmental

Durability (matings)	>500
Temperature range	-55 °C ~ +165 °C
RoHS Compliant	Yes

## Material & Finish

Body	Brass, Tri-Metal -plated
Pin Contact	Beryllium Copper Alloy, Gold-plated
Fastening Nut	Brass, Tri-Metal -plated
Washer	Phosphor Bronze , Tri-Metal -plated
Insulator	PTFE
Gasket	Silicone Rubber

## Interface Standards

SMA	IEC-60169
-----	-----------

REVISIONS				
REV	DESCRIPTION OF REVISION	ECN No.	DATE	APPROVED
A	INITIAL RELEASE		07/26/2019	M. Dong

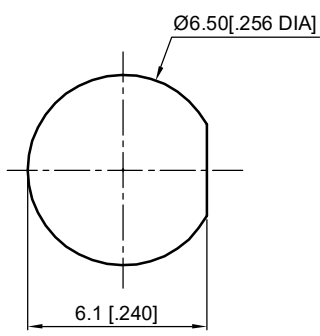
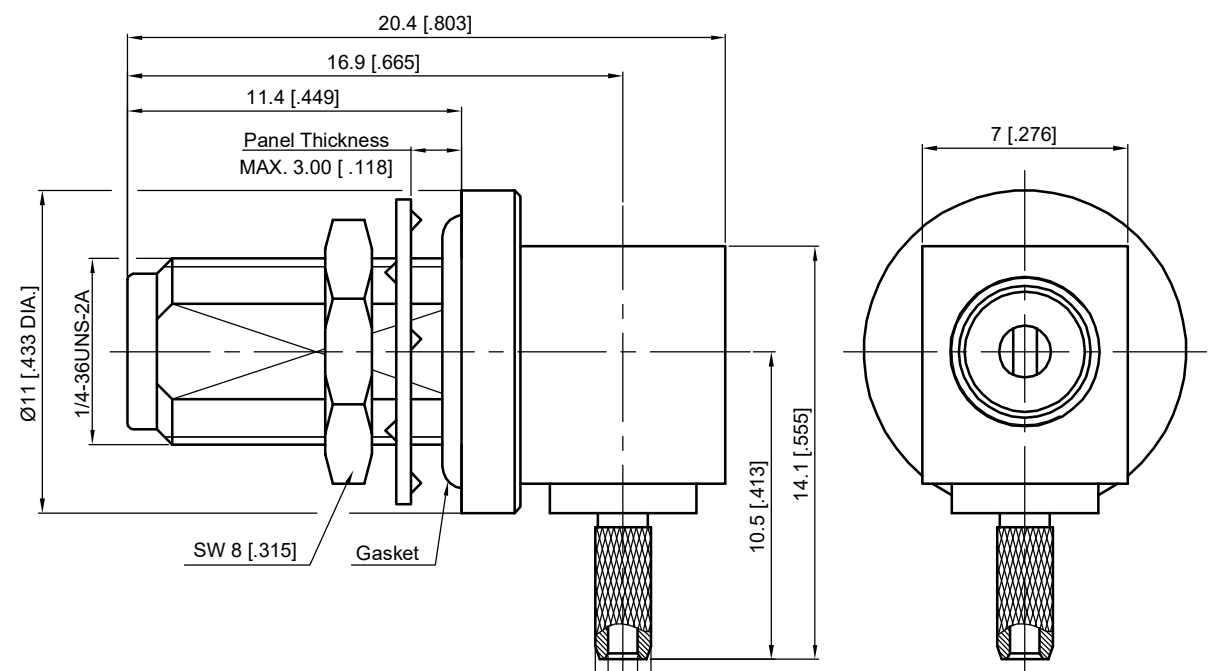

Recommended Mounting Hole

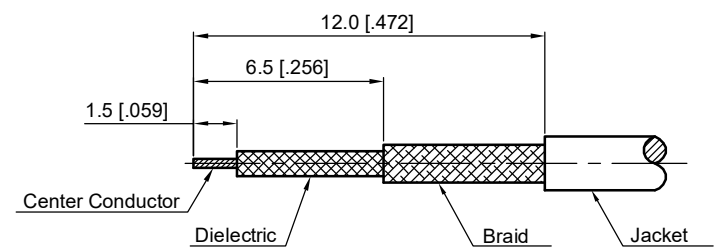

Recommended Cable Stripping Dimensions

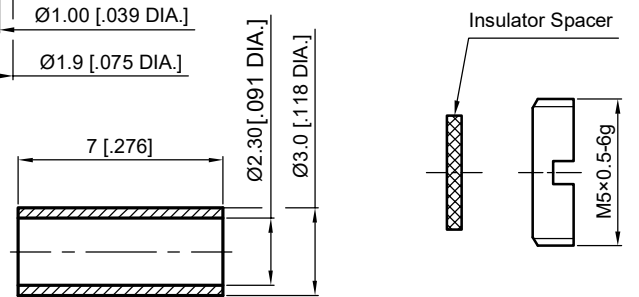

1. CRIMP FERRULE  
HEX. CRIMP TOOL SIZE: 2.54 [100]

NOTES:  
 1. ALL SPECIFICATIONS ARE SUBJECT TO CHANGE WITHOUT NOTICE AT ANY TIME  
 2. UNLESS OTHERWISE SPECIFIED ALL DIMENSIONS ARE NOMINAL.

UNLESS OTHERWISE SPECIFIED, DIMENSIONS ARE IN MILLIMETERS (INCHES). UNLESS OTHERWISE SPECIFIED DIMENSIONAL TOLERANCES ARE:

.XX	±0.13 [005"]
.X	±0.20 [008"]
X	±0.50 [019"]

ANGULAR TOLERANCES ARE: ALL= ±1°

DO NOT SCALE DRAWING

PROJECTION:

DRAWN:	L. Ma	07/26/2019
CHECKED:	J. Zhu	07/26/2019
APPROVED:	M. Dong	07/26/2019

TITLE:  
**SMA Right Angle Waterproof Bulkhead Female Crimp for RG178 Cable**

**CMP TER**<sup>®</sup>  
 Cmpter Electronics Co., Ltd. [www.cmpter.com](http://www.cmpter.com)

PART No.:  
**60-12-1D12-343**

SIZE: A4	SCALE: 4:1	SHEET: 1/1	REV: A
----------	------------	------------	--------