

TECHNICAL DATA

Electrical

Impedance	50 Ω
Frequency range	0~3 GHz
Withstanding voltage	750V
Insulation resistance	≥5000MΩ

Mechanical & Environmental

Durability (matings)	>500
Temperature range	-55 °C ~ +165 °C
RoHS Compliant	Yes

Material & Finish

Body	Brass, Gold-plated
Pin Contact	Phosphor Bronze, Gold-plated
Crimp Ferrule	Copper, Nickel-plated
Insulator	PTFE

Interface Standards

SMB	IEC-60169
-----	-----------

REVISIONS				
REV	DESCRIPTION OF REVISION	ECN No.	DATE	APPROVED
A	INITIAL RELEASE	---	04/12/2011	M. Dong
B	STRUCTURE CHANGED	---	11/07/2013	M. Dong
C	STRUCTURE CHANGED	---	04/25/2017	M. Dong

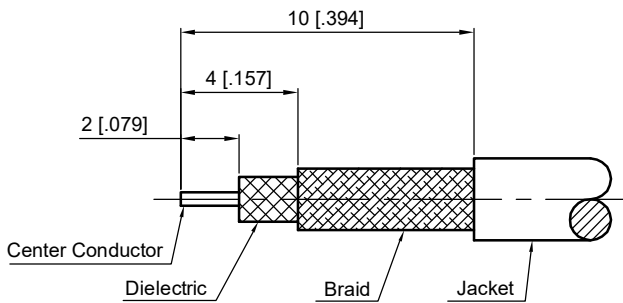
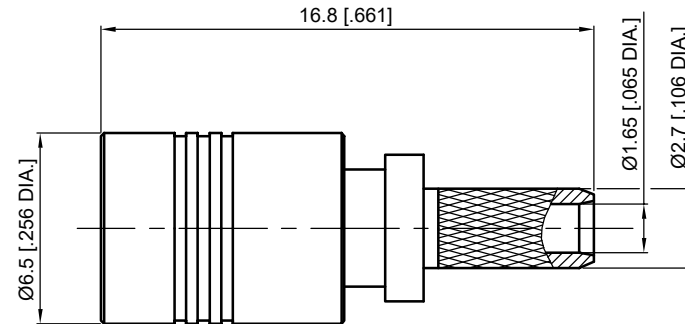

Recommended Cable Stripping Dimensions

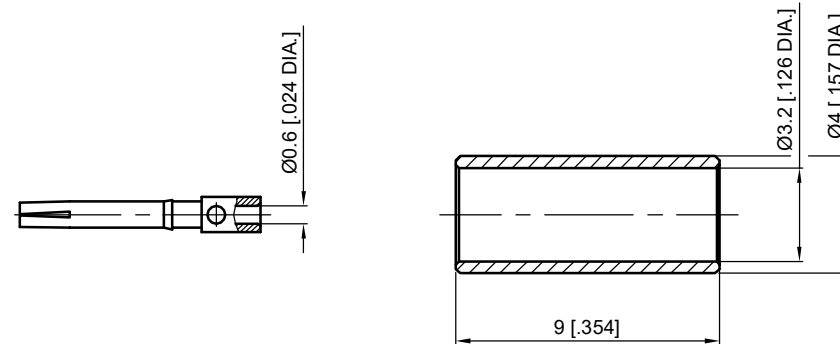

1. CRIMP FERRULE
HEX. CRIMP TOOL SIZE: 3.25 [128]

NOTES:

- ALL SPECIFICATIONS ARE SUBJECT TO CHANGE WITHOUT NOTICE AT ANY TIME
- UNLESS OTHERWISE SPECIFIED ALL DIMENSIONS ARE NOMINAL.

UNLESS OTHERWISE SPECIFIED, DIMENSIONS ARE IN MILLIMETERS [INCHES].
UNLESS OTHERWISE SPECIFIED DIMENSIONAL TOLERANCES ARE:

.XX	±0.13 [0.05"]
.X	±0.20 [0.08"]
X	±0.50 [0.19"]

ANGULAR TOLERANCES ARE: ALL = ±1°

DO NOT SCALE DRAWING

PROJECTION:



DRAWN:	L. Ma	04/25/2017
CHECKED:	J. Zhu	04/25/2017
APPROVED:	M. Dong	04/25/2017

TITLE:
SMB Straight Plug Crimp for LMR100/RG174/RG316 Cable



Cmppter Electronics Co., Ltd. www.cmppter.com

PART No.:
70-03-1M00-022

SIZE: A4	SCALE: 4:1	SHEET: 1/1	REV: C
-------------	---------------	---------------	-----------