

TECHNICAL DATA

Electrical

Impedance	50 Ω
Frequency range	0~3 GHz
Withstanding voltage	1000 V
Insulation resistance	≥5x10 ³ MΩ

Mechanical & Environmental

Durability (matings)	>500
Temperature range	-55 °C ~ +165 °C
RoHS Compliant	Yes

Material & Finish

Body	Brass, Nickel-plated
Pin Contact	Phosphor Bronze, Gold-plated
Fastening Nut	Brass, Nickel-plated
Crimp Ferrule	Copper, Nickel-plated
Insulator	PTFE
Gasket	Silicone Rubber

Interface Standards

TNC	IEC-60169
-----	-----------

REVISIONS				
REV	DESCRIPTION OF REVISION	ECN No.	DATE	APPROVED
A	INITIAL RELEASE	—	06/09/2014	M. Dong
B	SHOW PARTS DETAILS	—	05/04/2018	M. Dong

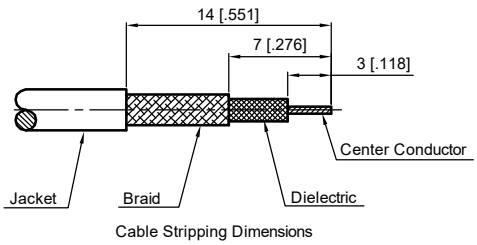
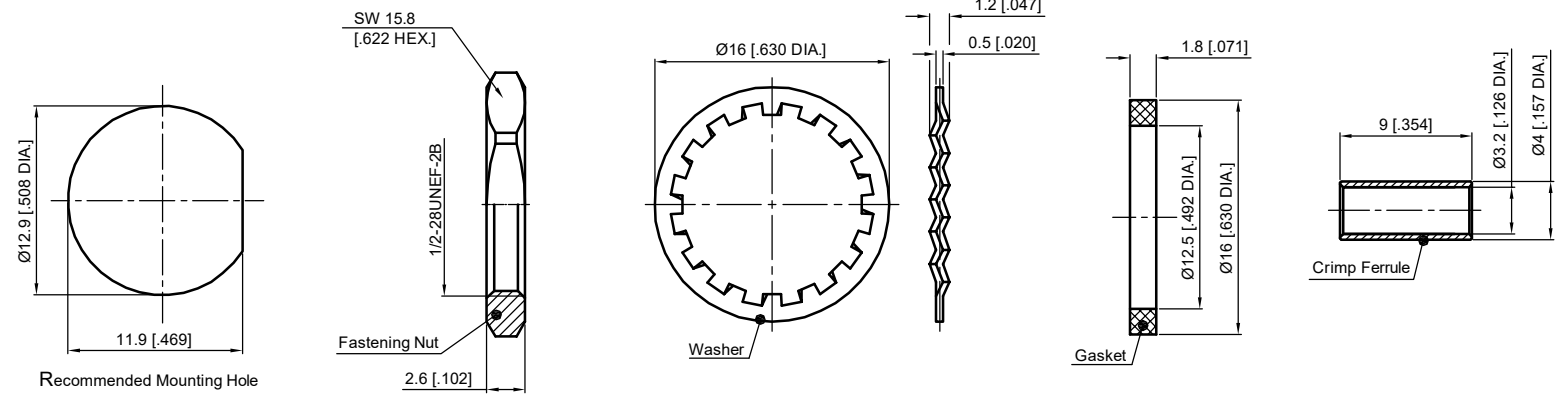
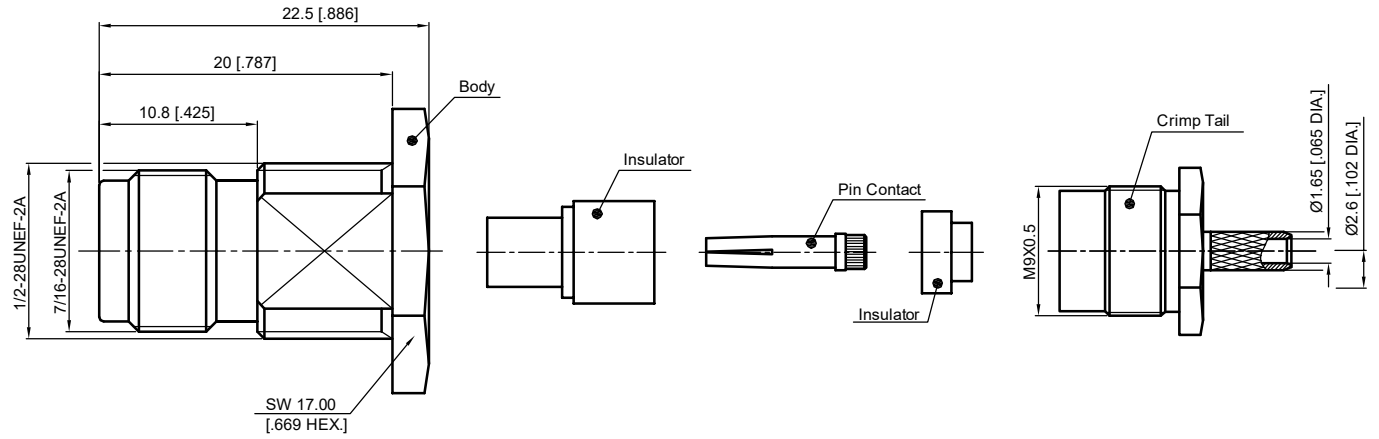

1. CRIMP FERRULE
HEX. CRIMP TOOL SIZE: 3.25 [.128]

- NOTES:
- ALL SPECIFICATIONS ARE SUBJECT TO CHANGE WITHOUT NOTICE AT ANY TIME
 - UNLESS OTHERWISE SPECIFIED ALL DIMENSIONS ARE NOMINAL.

UNLESS OTHERWISE SPECIFIED, DIMENSIONS ARE IN MILLIMETERS (INCHES). UNLESS OTHERWISE SPECIFIED DIMENSIONAL TOLERANCES ARE: .XX ±0.13 [.005"] .X ±0.20 [.008"] X ±0.50 [.019"] ANGULAR TOLERANCES ARE: ALL= ±1° DO NOT SCALE DRAWING	DRAWN:	L. Ma	05/04/2018
	CHECKED:	J. Zhu	05/04/2018
	APPROVED:	M. Dong	05/04/2018
PROJECTION:			
TITLE: TNC Straight Waterproof Bulkhead Female Crimp for LMR100/RG174/RG316 Cable			

CMP TER®
Cmpter Electronics Co., Ltd. www.cmpter.com

PART No.:
80-02-1D00-040

SIZE: A4	SCALE: 2.5:1	SHEET: 1/1	REV: B
----------	--------------	------------	--------