

REVISIONS

REV	DESCRIPTION OF REVISION	ECN No.	DATE	APPROVED
A	INITIAL RELEASE	—	04/20/2018	M. Dong

TECHNICAL DATA

Electrical

Impedance 50 Ω
 Frequency range 0~6 GHz
 Voltage Rating 500 Vrms
 Insulation resistance ≥5000MΩ

Mechanical & Environmental

Durability (matings) >500
 Temperature range -55 °C ~ +165 °C
 RoHS Compliant Yes

Material & Finish

Body Brass, Nickel-plated
 Pin Contact Phosphor Bronze, Gold-plated
 Insulator PTFE
 Gasket Silicone Rubber

Interface Standards

TNC IEC-60169

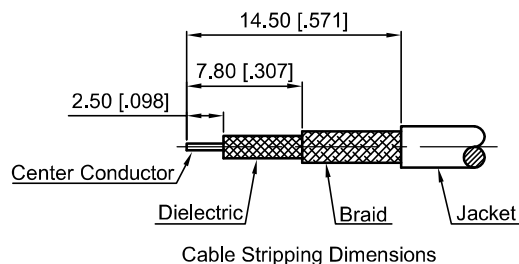
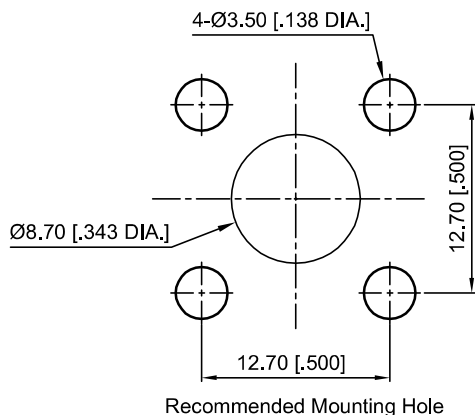
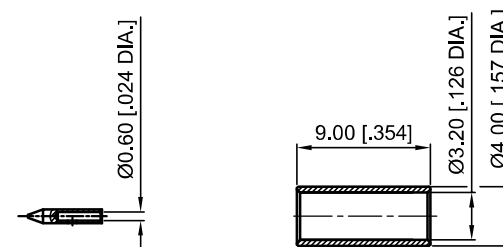
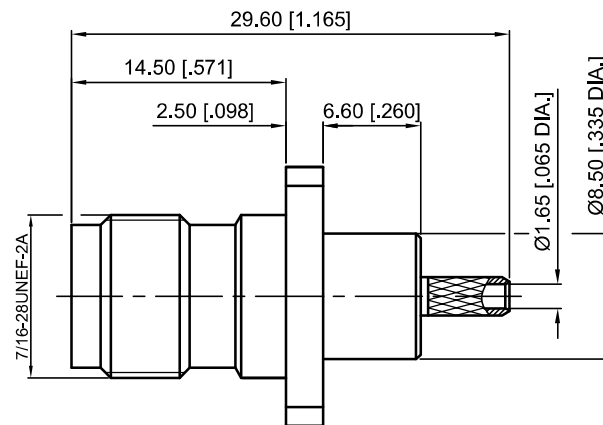
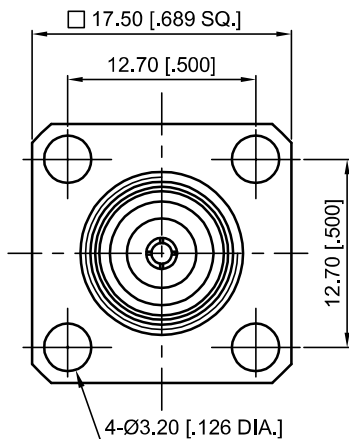

1. CRIMP FERRULE
 HEX.CRIMP TOOL SIZE: 3.25 [0.128]

- NOTES:
- ALL SPECIFICATIONS ARE SUBJECT TO CHANGE WITHOUT NOTICE AT ANY TIME
 - UNLESS OTHERWISE SPECIFIED ALL DIMENSIONS ARE NOMINAL.

UNLESS OTHERWISE SPECIFIED, DIMENSIONS ARE IN MILLIMETERS (INCHES). UNLESS OTHERWISE SPECIFIED DIMENSIONAL TOLERANCES ARE: .XX ±0.13 [0.005"] .X ±0.20 [0.008"] X ±0.50 [0.019"] ANGULAR TOLERANCES ARE: ALL=±1° DO NOT SCALE DRAWING	DRAWN:	L. Ma	04/20/2018
	CHECKED:	J. Zhu	04/20/2018
	APPROVED:	M. Dong	04/20/2018
	TITLE:	TNC Straight 4 Hole Flange Female Crimp for RG174/RG316/LMR100 Cable	
PROJECTION:			

CMPPTER[®]
 Cmptter Electronics Co., Ltd. www.cmptter.com

PART No.: **80-02-4F00-066**

SIZE: A4	SCALE: 2:1	SHEET: 1/1	REV: A
----------	------------	------------	--------