

REVISIONS				
REV	DESCRIPTION OF REVISION	ECN No.	DATE	APPROVED
A	INITIAL RELEASE		05/19/2016	M. Dong

TECHNICAL DATA

Electrical

Impedance	50 Ω
Frequency range	0~11 GHz
Withstanding voltage	1000 V
Insulation resistance	≥5x10 ³ MΩ

Mechanical & Environmental

Durability (matings)	>500
Temperature range	-55 °C ~ +165 °C
RoHS Compliant	Yes

Material & Finish

Body	Brass, Nickel-plated
Pin Contact	Phosphor Bronze, Gold-plated
Gasket	Silicone Rubber
Insulator	PTFE

Interface Standards

TNC	IEC-60169
-----	-----------

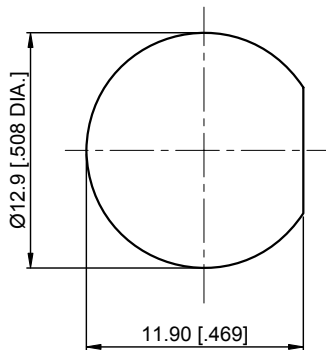
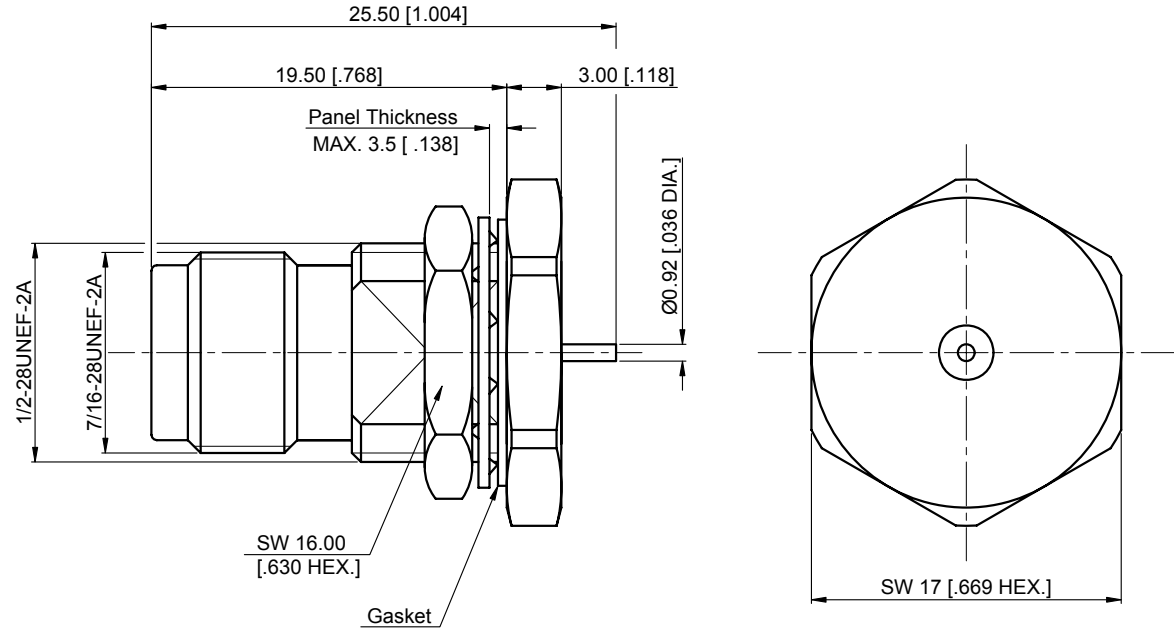

Recommended Mounting Hole

NOTES:

- ALL SPECIFICATIONS ARE SUBJECT TO CHANGE WITHOUT NOTICE AT ANY TIME
- UNLESS OTHERWISE SPECIFIED ALL DIMENSIONS ARE NOMINAL.

UNLESS OTHERWISE SPECIFIED, DIMENSIONS ARE IN MILLIMETERS (INCHES) UNLESS OTHERWISE SPECIFIED DIMENSIONAL TOLERANCES ARE:
 .XX ±0.13 [.005"]
 .X ±0.20 [.008"]
 X ±0.50 [.019"]

ANGULAR TOLERANCES ARE: ALL=±1°

DO NOT SCALE DRAWING

PROJECTION:

DRAWN:	L. Ma	05/19/2016
CHECKED:	J. Zhu	05/19/2016
APPROVED:	M. Dong	05/19/2016

TITLE:
TNC Straight Waterproof Bulkhead Female Connector

CMPPTER[®]

Cmptter Electronics Co., Ltd. www.cmptter.com

PART No.:
80-02-9D2-052

SIZE: A4	SCALE: 2.5:1	SHEET: 1/1	REV: A
-------------	-----------------	---------------	-----------